

terra
infrastructure

safety: efficient and sustainable

TRENCH SHORING TECHNICAL DATA

Trench shoring: Safety has the highest priority.

Every construction site has specific challenges that need to be mastered. However, the requirements of a shoring system are always strict in terms of providing safety, having a minimal impact on the soil outside the shoring, and allowing as much working space as possible.

For more than 70 years, our E+S and KRINGS brand shoring systems have provided cost-effective technical processing solutions with due regard to safety aspects for numerous civil engineering projects, both domestically and on overseas markets.

Unique expertise.

terra infrastructure is among the world's best-known providers of trench shoring. We offer a wide range of trench shoring equipment and supplementary products. Our portfolio also includes temporary construction site roads made of steel or plastic.

For many construction projects, it is more economical to hire the shoring system. Our extensive range of rental equipment means we can always provide our customers with a suitable system, even for large-scale projects.

Contents

02	Boxes
40	Linear shoring
70	Supplementary products



System overview – Box systems

Recommended shoring depth: max. 3.50 m

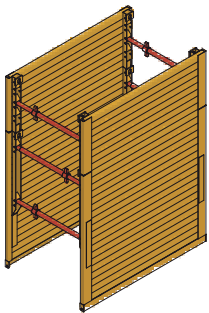

KRINGSKVL
Rec. shoring depth: max. 3.50 m
Page 4

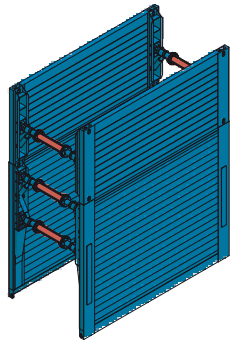

E+SLBR
Rec. shoring depth: max. 3.50 m
Page 6

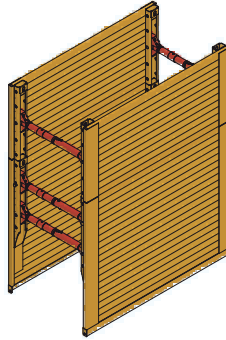

KRINGS KS 60
Rec. shoring depth: max. 3.50 m
Page 8

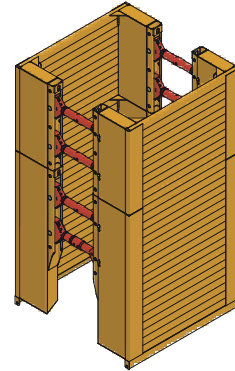

KRINGS KS 60 Manhole
Rec. shoring depth: max. 3.50 m
Page 10

Recommended shoring depth: max. 4.00 m

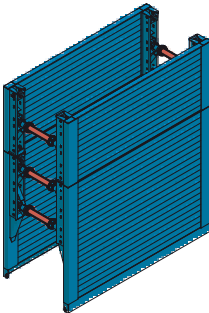

E+S Medium
Rec. shoring depth: max. 5.00 m
Page 12

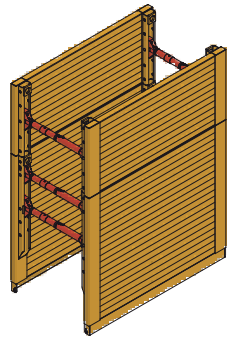

KRINGS KS 100
Rec. shoring depth: max. 4.00 m
Page 14

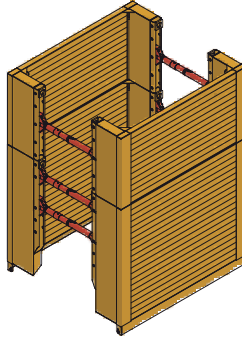

KRINGS KS 100 Manhole
Rec. shoring depth: max. 4.00 m
Page 16

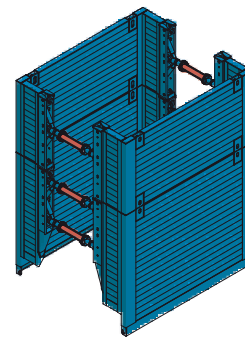

E+S Manhole
Rec. shoring depth: max. 4.00 m
Page 18

Recommended shoring depth: max. 6.00 m

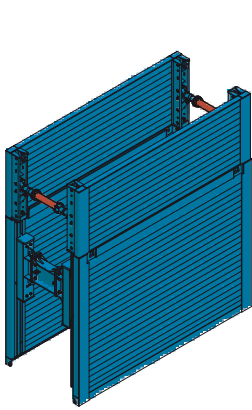

E+S Linear box
 Rec. shoring depth: max. 5.00 m
 Page 20

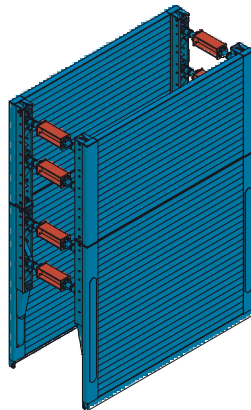

E+S Magnum
 Rec. shoring depth: max. 6.00 m
 Page 22

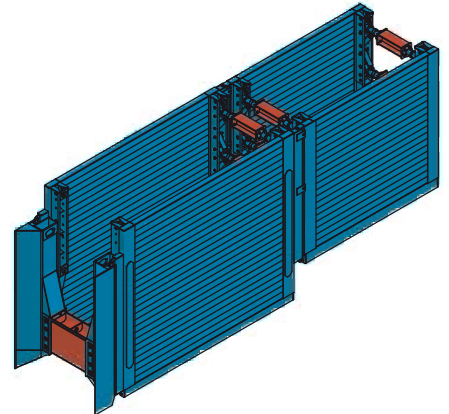

E+S Dragbox
 Rec. shoring depth: max. 5.00 m
 Page 26

Recommended shoring depth: variable

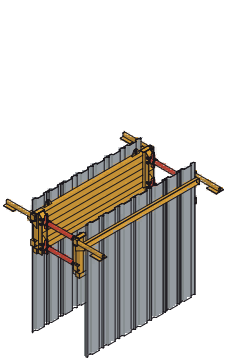

KRINGSBLU
 Rec. shoring depth: max. 2.50 m
 Page 28

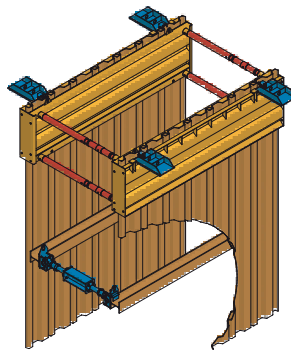

KRINGSDKU 2.27+3.81
 Rec. shoring depth: variable
 Page 30

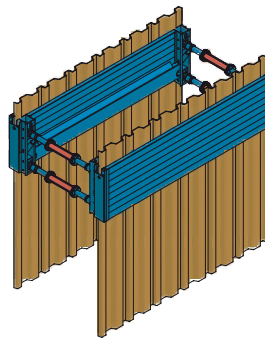

E+S DKE 3.63+4.03
 Rec. shoring depth: variable
 Page 32

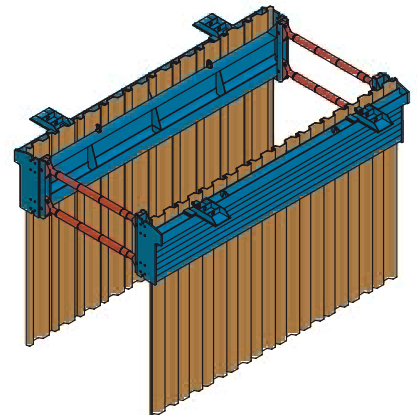

KRINGSDKU 5.80
 Rec. shoring depth: variable
 Page 33

Recommended installation depth: max. 3.00 m

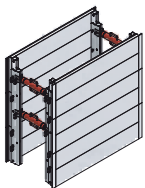

Aluminum lightweight shoring
 Rec. shoring depth: max. 3.00 m
 Page 34

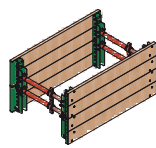

KRINGS Flex shoring
 Rec. shoring depth: max. 2.00 m
 Page 36

KRINGS KVL lightweight shoring



General data

Shoring length	2.00 m–3.50 m
Base unit height	1.50 m / 2.00 m / 2.40 m
Top unit height	0.50 m / 1.00 m
Pipe culvert height	0.72 m / 0.97 m / 1.30 m
Base box weight	527 kg–1,123 kg
Shoring width	variable

KVL spindle 70 x ...

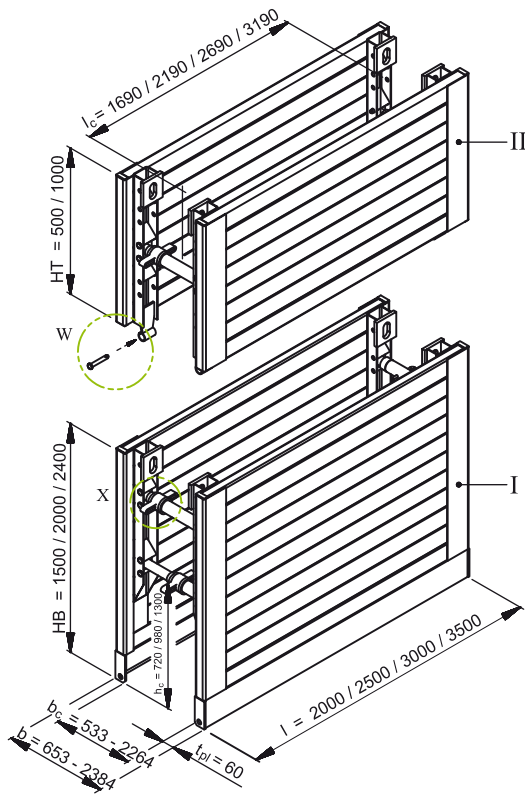

KVL mit spindle 98 x ... and adapter

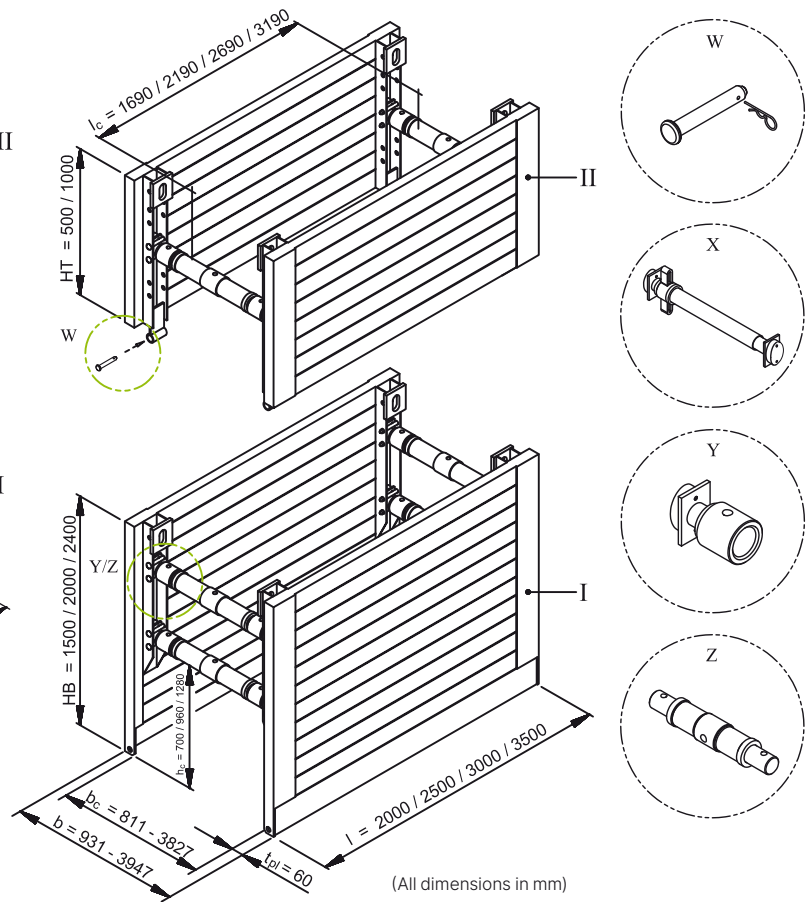

- | | | | | | | | |
|----|------------------|----|----------------------|-----|---------------------|---|------------------|
| I | Base unit | l | Length | hc | Pipe culvert height | X | KVL spindle |
| II | Top unit | lc | Pipe culvert length | tpl | Panel thickness | Y | Adapter |
| HB | Base unit height | b | Shoring/trench width | W | Bolt | Z | Spindle 98 x ... |
| HT | Top unit height | bc | Clear width | | | | |

Base units

Art. no.	l [m]	h [m]	t _{pl} [m]	h _c [m]	l _c [m]	G / VP [kg]	G / Box [kg]	A [m ²]	eh [kN/m ²]
111 030	2.00	1.50	0.06	0.72	1.69	235.0	527.0 *	3.00	57.9
111 050	2.50	1.50	0.06	0.72	2.19	252.0	561.0 *	3.75	38.2
111 080	3.00	1.50	0.06	0.72	2.69	310.0	677.0 *	4.50	25.5
111 040	2.00	2.00	0.06	0.98	1.69	295.0	647.0 *	4.00	32.2
111 060	2.50	2.00	0.06	0.98	2.19	350.0	757.0 *	5.00	25.7
111 090	3.00	2.00	0.06	0.98	2.69	400.0	857.0 *	6.00	21.4
111 092	3.50	2.00	0.06	0.98	3.19	465.0	987.0 *	7.00	18.3
111 091	3.00	2.40	0.06	1.30	2.69	470.0	997.0 *	7.20	21.6
111 093	3.50	2.40	0.06	1.30	3.19	533.0	1,123.0 *	8.40	18.3

* With spindle 70 × 650

Top units

Art. no.	l [m]	h [m]	t _{pl} [m]	h _c [m]	l _c [m]	G / VP [kg]	G / Box [kg]	A [m ²]	eh [kN/m ²]
111 130	2.00	0.50	0.06	-	1.69	92.0	214.0 *	1.00	63.5
111 150	2.50	0.50	0.06	-	2.19	105.0	240.0 *	1.25	38.2
111 170	3.00	0.50	0.06	-	2.69	130.0	290.0 *	1.50	25.5
111 172	3.50	0.50	0.06	-	3.19	150.0	330.4 *	1.75	18.3
111 120	2.00	1.00	0.06	-	1.69	165.0	360.0 *	2.00	63.5
111 140	2.50	1.00	0.06	-	2.19	195.0	420.0 *	2.50	38.2
111 160	3.00	1.00	0.06	-	2.69	217.0	464.0 *	3.00	25.5
111 174	3.50	1.00	0.06	-	3.19	245.0	520.4 *	3.50	18.3

* With spindle 70 × 650

Shoring widths for spindle 70 × ...

Art. no.	Short description	Lift [m]	b _c [m]	b [m]	G [kg]
118 060	Spindle 70 × 650	0.094	0.533–0.627	0.653–0.747	12.2
118 070	Spindle 70 × 740	0.184	0.623–0.807	0.743–0.927	13.4
118 090	Spindle 70 × 920	0.362	0.809–1.171	0.929–1.291	15.8
118 020	Spindle 70 × 1280	0.725	1.163–1.888	1.283–2.008	20.5
118 100	Spindle 70 × 1470	0.915	1.349–2.264	1.469–2.384	24.0

Shoring widths for spindle 98 × 550 with adapter

Extension bar	l [m]	b _c [m]	b [m]
	w/o	0.811–1.011	0.931–1.131
139 430	0.30	1.111–1.311	1.231–1.431
139 445	0.50	1.311–1.511	1.431–1.631
139 385	1.00	1.811–2.011	1.931–2.131
139 400	1.50	2.311–2.511	2.431–2.631
139 420	2.00	2.811–3.011	2.931–3.131
139 425	2.50	3.311–3.511	3.431–3.631

Shoring widths for spindle 98 × 700 with adapter

Extension bar	l [m]	b _c [m]	b [m]
	w/o	0.987–1.327	1.107–1.447
139 430	0.30	1.287–1.627	1.407–1.747
139 445	0.50	1.487–1.827	1.607–1.947
139 385	1.00	1.987–2.327	2.107–2.447
139 400	1.50	2.487–2.827	2.607–2.947
139 420	2.00	2.987–3.327	3.107–3.447
139 425	2.50	3.487–3.827	3.607–3.947

l	Length	b _c	Clear width	t _{pl}	Panel thickness	G / VP	Weight / shoring panel
l _c	Pipe culvert length	h	Panel height	A	Surface	G / Box	Weight / shoring box
b	Trench width	h _c	Pipe culvert height	G	Weight	eh	Admissible soil pressure

E+S LBR lightweight shoring

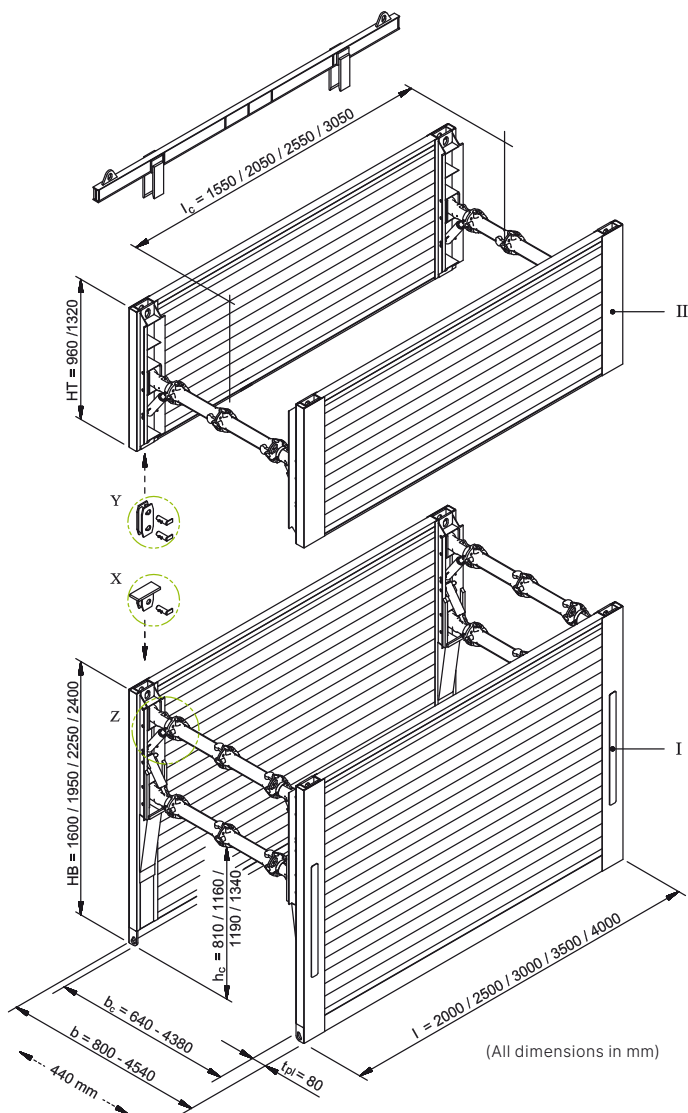

General data

Shoring length	2.00 m–4.00 m
Base unit height	1.60 m / 1.95 m / 2.25 m / 2.40 m
Top unit height	0.96 m / 1.32 m
Pipe culvert height	0.81 m / 1.16 m / 1.19 m / 1.34 m
Base box weight	746 kg–1,960 kg
Shoring width	variable

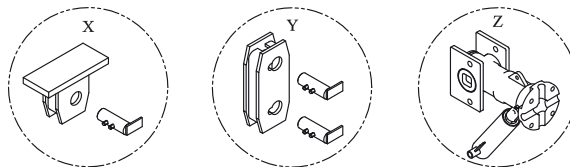

- I Base unit
- II Top unit
- HB Base unit height
- HT Top unit height
- l Length
- lc Pipe culvert length
- b Shoring/trench width
- bc Clear width
- hc Pipe culvert height
- tpi Panel thickness
- X Pressure panel with bolts
- Y Connector with bolts
- Z Strut with bearing panel and stabilizer

Base units (height 1.60 m)

Art. no.	l [m]	tpi [m]	hc [m]	lc [m]	G / VP [kg]	G / Box [kg]	A [m ²]	eh [kN/m ²]
801 455	2.00	0.08	0.81	1.55	373.0	746.0	3.20	70.5
801 505	2.50	0.08	0.81	2.05	420.0	840.0	4.00	50.9
801 568	3.00	0.08	0.81	2.55	502.0	1,004.0	4.80	34.0
801 578	3.50	0.08	0.81	3.05	538.0	1,076.0	5.60	24.3

Base units (height 1.95 m)

Art. no.	l [m]	tpi [m]	hc [m]	lc [m]	G / VP [kg]	G / Box [kg]	A [m ²]	eh [kN/m ²]
801 475	2.00	0.08	1.16	1.55	467.0	934.0	3.90	58.3
801 525	2.50	0.08	1.16	2.05	478.0	956.0	4.88	46.6
801 565	3.00	0.08	1.16	2.55	588.0	1,176.0	5.85	34.0
801 575	3.50	0.08	1.16	3.05	618.0	1,236.0	6.83	24.3
801 590	4.00	0.08	1.19	3.55	798.0	1,596.0	7.80	18.6

Base units (height 2.25 m)

Art. no.	l [m]	t _{pl} [m]	h _c [m]	l _c [m]	G / VP [kg]	G / Box [kg]	A [m ²]	eh [kN/m ²]
801 015	2.00	0.08	1.19	1.55	515.0	1,030.0	4.50	61.1
801 055	2.50	0.08	1.19	2.05	595.0	1,190.0	5.63	48.9
801 105	3.00	0.08	1.19	2.55	670.0	1,340.0	6.75	34.0
801 108	3.50	0.08	1.19	3.05	740.0	1,480.0	7.88	24.3
801 109	4.00	0.08	1.19	3.55	950.0	1,900.0	9.00	18.6

Base units (height 2.40 m)

Art. no.	l [m]	t _{pl} [m]	h _c [m]	l _c [m]	G / VP [kg]	G / Box [kg]	A [m ²]	eh [kN/m ²]
801 210	2.00	0.08	1.34	1.55	550.0	1,100.0	4.80	50.6
801 215	2.50	0.08	1.34	2.05	655.0	1,310.0	6.00	40.5
801 220	3.00	0.08	1.34	2.55	675.0	1,350.0	7.20	34.0
801 110	3.50	0.08	1.34	3.05	770.0	1,540.0	8.40	24.3
801 115	4.00	0.08	1.34	3.55	980.0	1,960.0	9.60	18.6

Top units (height 0.96 m)

Art. no.	l [m]	t _{pl} [m]	h _c [m]	l _c [m]	G / VP [kg]	G / Box [kg]	A [m ²]	eh [kN/m ²]
801 595	2.00	0.08	-	1.55	265.0	530.0	1.92	70.5
801 625	2.50	0.08	-	2.05	317.0	634.0	2.40	50.9
801 665	3.00	0.08	-	2.55	357.0	714.0	2.88	34.0
801 675	3.50	0.08	-	3.05	380.0	760.0	3.36	24.3
801 676	4.00	0.08	-	3.55	465.0	930.0	3.84	18.6

Top units (height 1.32 m)

Art. no.	l [m]	t _{pl} [m]	h _c [m]	l _c [m]	G / VP [kg]	G / Box [kg]	A [m ²]	eh [kN/m ²]
801 628	2.00	0.08	-	1.55	341.0	682.0	2.64	70.5
801 630	2.50	0.08	-	2.05	391.0	782.0	3.30	50.9
801 635	3.00	0.08	-	2.55	408.0	816.0	3.96	34.0
801 680	3.50	0.08	-	3.05	430.0	860.0	4.62	24.3
801 678	4.00	0.08	-	3.55	573.0	1,146.0	5.28	18.6

Extension bars

Art. no.	Short description	l [m]	G [kg]
850 091	Cast extension bar	0.250	11.2
850 100	Cast extension bar	0.550	18.7
850 112	HEB 180 extension bar	0.275	28.0
850 110	HEB 180 extension bar	0.550	43.0
850 124	HEB 180 extension bar	1.100	70.0
850 132	HEB 180 extension bar	1.650	100.0
850 135	HEB 180 extension bar	2.200	130.0

Shoring width (for cast pipe extension bars, l = 0.55 m)

Extension bars	Extension bar length [m]	b _c [m]	b [m]
0	0.00	0.64–1.08	0.80–1.24
1	0.55	1.19–1.63	1.35–1.79
2	1.10	1.74–2.18	1.90–2.34
3	1.65	2.29–2.73	2.45–2.89
4	2.20	2.84–3.28	3.00–3.44
5	2.75	3.39–3.83	3.55–3.99
max. 6	3.30	3.94–4.38	4.10–4.54

Dimensions "from-to" depending on spindle stroke.
Different trench widths possible by combination of different extension bar lengths l = 0.25 m and l = 0.55 m.

l	Length	b _c	Clear width	A	Surface	G / Box	Weight / shoring box
l _c	Pipe culvert length	h _c	Pipe culvert height	G	Weight	eh	Admissible soil pressure
b	Trench width	t _{pl}	Panel thickness	G / VP	Weight / shoring panel		

KRINGS KS 60



General data

Shoring length	2.00 m–4.00 m
Base unit height	2.00 m / 2.40 m
Top unit height	1.00 m / 1.30 m
Pipe culvert height	0.995 m / 1.355 m
Base box weight	980 kg–1,580 kg
Shoring width	variable

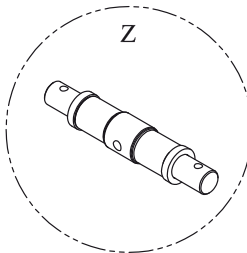
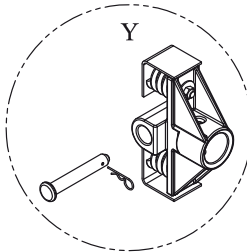
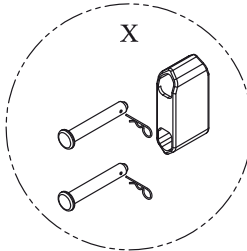
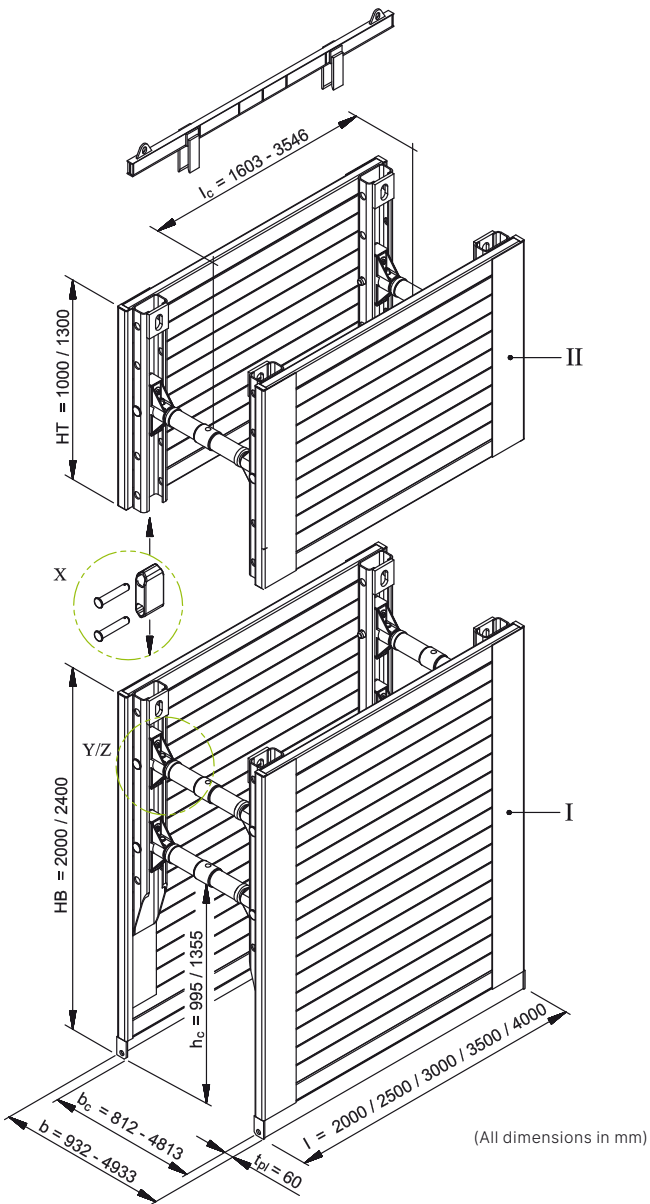

- | | | | | | | | |
|----|------------------|----------------|----------------------|-----------------|--------------------------|---|------------------|
| I | Base unit | l | Length | h _c | Pipe culvert height | Z | Spindle 98 x ... |
| II | Top unit | l _c | Pipe culvert length | t _{pl} | Panel thickness | | |
| HB | Base unit height | b | Shoring/trench width | X | Connector with bolts | | |
| HT | Top unit height | b _c | Clear width | Y | Spring socket with bolts | | |

Base units

Art. no.	l [m]	h [m]	t _{pl} [m]	h _c [m]	l _c [m]	G / VP [kg]	G / Box [kg]	A [m ²]	eh [kN/m ²]
131 030	2.00	2.00	0.06	0.995	1.61	350.0	980.0 *	4.00	59.5
131 035	2.50	2.00	0.06	0.995	2.11	420.0	1,120.0 *	5.00	39.7
131 060	3.00	2.00	0.06	0.995	2.61	460.0	1,200.0 *	6.00	26.3
131 080	3.50	2.00	0.06	0.995	3.05	560.0	1,400.0 *	7.00	26.6
131 085	4.00	2.00	0.06	0.995	3.61	665.0	1,610.0 *	8.00	19.8
131 040	2.00	2.40	0.06	1.355	1.61	394.0	1,068.0 *	4.80	39.1
131 050	2.50	2.40	0.06	1.355	2.11	460.0	1,200.0 *	6.00	31.3
131 070	3.00	2.40	0.06	1.355	2.61	515.0	1,310.0 *	7.20	26.1
131 090	3.50	2.40	0.06	1.355	3.05	650.0	1,580.0 *	8.40	22.3

* With spindle 98 × 700

Top units

Art. no.	l [m]	h [m]	t _{pl} [m]	h _c [m]	l _c [m]	G / VP [kg]	G / Box [kg]	A [m ²]	eh [kN/m ²]
131 135	2.50	1.00	0.06	-	2.11	235.0	652.0 *	2.50	39.7
131 140	3.00	1.00	0.06	-	2.61	265.0	712.0 *	3.00	26.3
131 160	3.50	1.00	0.06	-	3.05	333.0	848.0 *	3.50	26.6
131 120	2.00	1.30	0.06	-	1.61	260.0	702.0 *	2.60	66.7
131 130	2.50	1.30	0.06	-	2.11	295.0	772.0 *	3.25	39.7
131 150	3.00	1.30	0.06	-	2.61	330.0	842.0 *	3.90	26.3
131 170	3.50	1.30	0.06	-	3.05	395.0	972.0 *	4.55	26.6

* With spindle 98 × 700

Shoring widths for spindle 98 × 550

Extension bar	l [m]	b _c [m]	b [m]
	w/o	0.812–1.012	0.932–1.132
139 430	0.30	1.112–1.312	1.232–1.432
139 445	0.50	1.312–1.512	1.432–1.632
139 385	1.00	1.812–2.012	1.932–2.132
139 400	1.50	2.313–2.512	2.432–2.632
139 420	2.00	2.812–3.012	2.932–3.132
139 425	2.50	3.312–3.512	3.432–3.632

Shoring widths for spindle 98 × 700

Extension bar	l [m]	b _c [m]	b [m]
	w/o	0.988–1.328	1.108–1.448
139 430	0.30	1.288–1.628	1.408–1.748
139 445	0.50	1.488–1.828	1.608–1.948
139 385	1.00	1.988–2.328	2.108–2.448
139 400	1.50	2.488–2.828	2.608–2.948
139 420	2.00	2.988–3.328	3.108–3.448
139 425	2.50	3.488–3.828	3.608–3.948

l	Length	b _c	Clear width	t _{pl}	Panel thickness	G / Box	Weight / shoring box
l _c	Pipe culvert length	h	Panel height	A	Surface	eh	Admissible soil pressure
b	Trench width	h _c	Pipe culvert height	G / VP	Weight / shoring panel		

KRINGS KS 60 Manhole

General data

Shoring length	2.00 m–4.00 m
Base unit height	2.00 m / 2.40 m
Top unit height	1.00 m / 1.30 m
Pipe culvert height	0.995 m / 1.355 m
Base box weight	1,380 kg–2,050 kg
Shoring width	variable

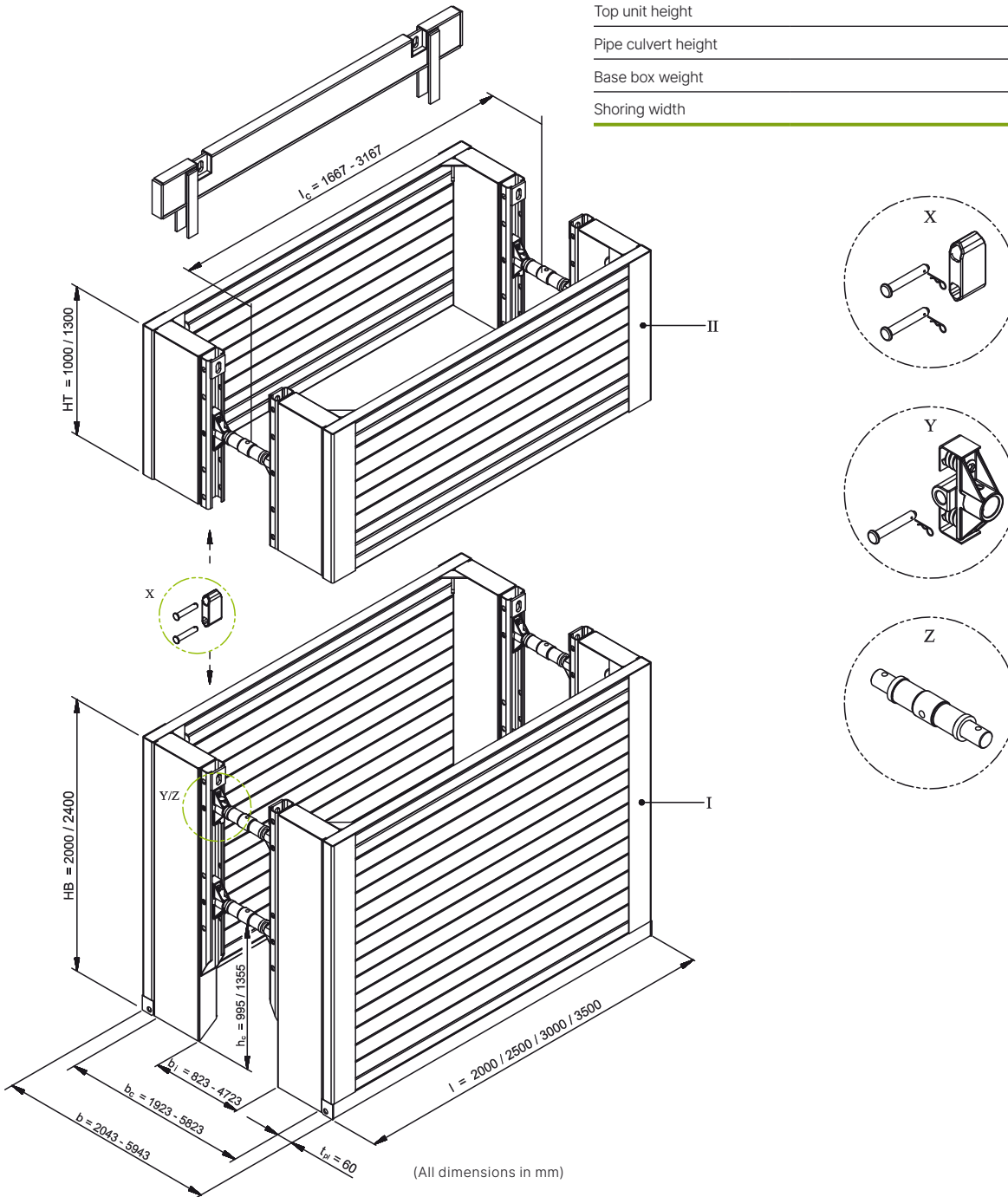

I	Base unit	l	Length	b _i	Clear passage width	X	Connector with bolts
II	Top unit	l _c	Pipe culvert length	h _c	Pipe culvert height	Y	Spring socket with bolts
HB	Base unit height	b	Shoring/trench width	t _{pl}	Panel thickness	Z	Spindle 98 x ...
HT	Top unit height	b _c	Clear width				

Base units

Art. no.	l [m]	h [m]	t _{pl} [m]	h _c [m]	l _c [m]	G / VP [kg]	G / Box [kg]	A [m ²]	eh [kN/m ²]
135 208	2.00	2.00	0.06	0.995	1.61	550.0	1,380.0 *	4.00	59.5
135 209	2.50	2.00	0.06	0.995	2.11	605.0	1,490.0 *	5.00	39.7
135 211	3.00	2.00	0.06	0.995	2.61	660.0	1,600.0 *	6.00	26.3
135 212	3.50	2.00	0.06	0.995	3.05	770.0	1,820.0 *	7.00	26.6
135 213	4.00	2.00	0.06	0.995	3.61	840.0	1,960.0 *	8.00	19.8
135 206	2.00	2.40	0.06	1.355	1.61	631.0	1,542.0 *	4.80	39.1
135 205	2.50	2.40	0.06	1.355	2.11	693.0	1,666.0 *	6.00	31.3
135 200	3.00	2.40	0.06	1.355	2.61	755.0	1,790.0 *	7.20	26.1
135 199	3.50	2.40	0.06	1.355	3.05	885.0	2,050.0 *	8.40	22.3

* With spindle 98 × 700

Top units

Art. no.	l [m]	h [m]	t _{pl} [m]	h _c [m]	l _c [m]	G / VP [kg]	G / Box [kg]	A [m ²]	eh [kN/m ²]
135 284	2.00	1.00	0.06	-	1.61	340.0	862.0 *	2.00	66.7
135 283	2.50	1.00	0.06	-	2.11	370.0	916.0 *	2.50	39.7
135 300	3.00	1.00	0.06	-	2.61	400.0	982.0 *	3.00	26.3
135 301	3.50	1.00	0.06	-	3.05	455.0	1,092.0 *	3.50	26.6
135 285	2.00	1.30	0.06	-	1.61	430.0	1,043.0 *	2.60	66.7
135 286	2.50	1.30	0.06	-	2.11	470.0	1,122.0 *	3.25	39.7
135 290	3.00	1.30	0.06	-	2.61	505.0	1,192.0 *	3.90	26.3
135 291	3.50	1.30	0.06	-	3.05	580.0	1,342.0 *	4.55	26.6

* With spindle 98 × 700

Shoring widths for spindle 98 × 550

Extension bar	l [m]	b _i [m]	b _c [m]	b [m]
	w/o	0.616–0.816	1.820–2.020	2.042–2.242
139 430	0.30	0.916–1.116	2.120–2.320	2.342–2.542
139 445	0.50	1.116–1.316	2.320–2.520	2.542–2.742
139 385	1.00	1.616–1.816	2.820–3.020	3.042–3.242
139 400	1.50	2.116–2.316	3.320–3.520	3.542–3.742
139 420	2.00	2.616–2.816	3.820–4.020	4.042–4.242
139 425	2.50	3.116–3.316	4.320–4.520	4.542–4.742

Shoring widths for spindle 98 × 700

Extension bar	l [m]	b _i [m]	b _c [m]	b [m]
	w/o	0.792–1.132	1.996–2.336	2.218–2.558
139 430	0.30	1.092–1.432	2.296–2.636	2.518–2.858
139 445	0.50	1.292–1.632	2.496–2.836	2.718–3.058
139 385	1.00	1.792–2.132	2.996–3.336	3.218–3.558
139 400	1.50	2.292–2.632	3.496–3.836	3.718–4.058
139 420	2.00	2.792–3.132	3.996–4.336	4.218–4.558
139 425	2.50	3.292–3.632	4.496–4.836	4.718–5.058

l	Length
l _c	Pipe culvert length
b	Trench width
b _c	Clear width
h	Panel height
h _c	Pipe culvert height
t _{pl}	Panel thickness
A	Surface
G / VP	Weight / shoring panel
G / Box	Weight / shoring box
eh	Admissible soil pressure

E+S Medium shoring



General data

Shoring length	2.00 m–4.50 m
Base unit height	2.60 m
Top unit height	1.32 m / 2.00 m
Pipe culvert height	1.45 m
Base box weight	1,460 kg–2,780 kg
Shoring width	variable

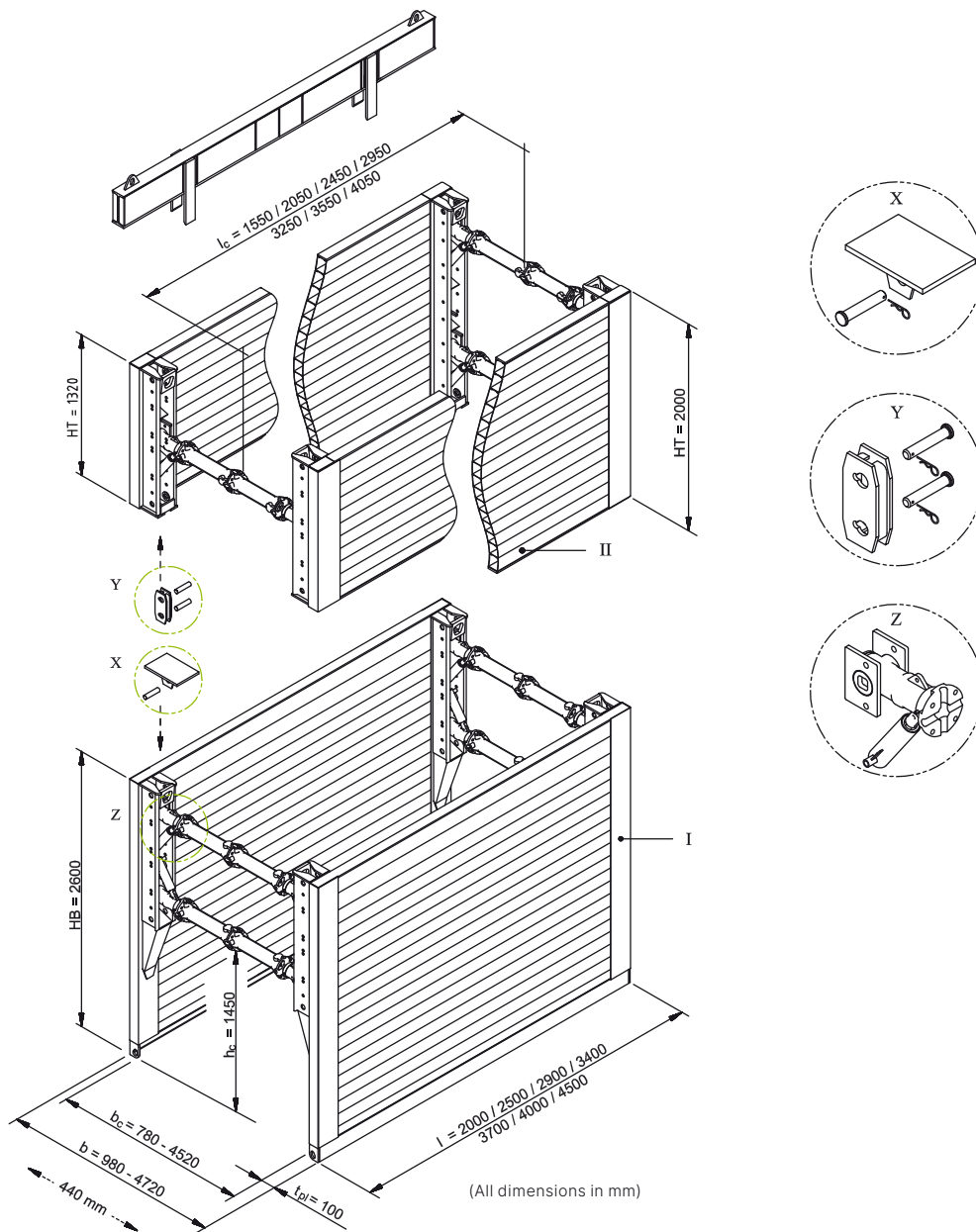

- | | | | | | | | |
|----|------------------|----|----------------------|-----|---------------------------|---|---|
| I | Base unit | l | Length | hc | Pipe culvert height | Z | Strut with bearing panel and stabilizer |
| II | Top unit | lc | Pipe culvert length | tpl | Panel thickness | | |
| HB | Base unit height | b | Shoring/trench width | X | Pressure panel with bolts | | |
| HT | Top unit height | bc | Clear width | Y | Connector with bolts | | |

Base units (height 2.60 m)

Art. no.	l [m]	t _{pl} [m]	h _c [m]	l _c [m]	G / VP [kg]	G / Box [kg]	A [m ²]	eh [kN/m ²]
800 010	2.00	0.10	1.45	1.55	730.0	1,460.0	5.20	70.0
800 100	2.50	0.10	1.45	2.05	825.0	1,650.0	6.50	60.0
800 150	2.90	0.10	1.45	2.45	908.0	1,816.0	7.54	55.0
800 200	3.40	0.10	1.45	2.95	1,028.0	2,056.0	8.84	50.8
800 300	3.70	0.10	1.45	3.25	1,118.0	2,236.0	9.62	42.3
800 400	4.00	0.10	1.45	3.55	1,257.0	2,514.0	10.40	44.0
800 440	4.50	0.10	1.45	4.05	1,390.0	2,780.0	11.70	34.2

Top units (height 1.32 m)

Art. no.	l [m]	t _{pl} [m]	h _c [m]	l _c [m]	G / VP [kg]	G / Box [kg]	A [m ²]	eh [kN/m ²]
800 550	2.00	0.10	-	1.55	463.0	926.0	2.64	165.0
800 600	2.50	0.10	-	2.05	531.0	1,062.0	3.30	99.3
800 650	2.90	0.10	-	2.45	578.0	1,156.0	3.83	71.5
800 700	3.40	0.10	-	2.95	658.0	1,316.0	4.49	50.5
800 800	3.70	0.10	-	3.25	692.0	1,384.0	4.88	42.1
800 900	4.00	0.10	-	3.55	775.0	1,550.0	5.28	43.8
800 950	4.50	0.10	-	4.05	820.0	1,640.0	5.94	34.2

Top units (height 2.00 m)

Art. no.	l [m]	t _{pl} [m]	h _c [m]	l _c [m]	G / VP [kg]	G / Box [kg]	A [m ²]	eh [kN/m ²]
802 680	2.00	0.10	-	1.55	697.0	1,394.0	4.00	165.0
802 690	2.50	0.10	-	2.05	785.0	1,570.0	5.00	99.3
802 550	2.90	0.10	-	2.45	840.0	1,680.0	5.80	71.5
802 700	3.40	0.10	-	2.95	930.0	1,860.0	6.80	50.5
802 750	3.70	0.10	-	3.25	990.0	1,980.0	7.40	42.1
802 751	4.00	0.10	-	3.55	1,085.0	2,170.0	8.00	43.8
800 951	4.50	0.10	-	4.05	1,192.0	2,384.0	9.00	34.2

Extension bars

Art. no.	Short description	l [m]	G [kg]
850 091	Cast extension bar	0.250	11.2
850 100	Cast extension bar	0.550	18.7
850 112	HEB 180 extension bar	0.275	28.0
850 110	HEB 180 extension bar	0.550	43.0
850 124	HEB 180 extension bar	1.100	70.0
850 132	HEB 180 extension bar	1.650	100.0
850 135	HEB 180 extension bar	2.200	130.0

Shoring widths (for cast pipe extension bars, l = 0.55 m)

Extension bars	Extension bar length [m]	b _c [m]	b [m]
0	0.00	0.78–1.22	0.98–1.42
1	0.55	1.33–1.77	1.53–1.97
2	1.10	1.88–2.32	2.08–2.52
3	1.65	2.43–2.87	2.63–3.07
4	2.20	2.98–3.42	3.18–3.62
5	2.75	3.53–3.97	3.73–4.17
max. 6	3.30	4.08–4.52	4.28–4.72

Dimensions "from-to" depending on spindle stroke.
Other trench widths possible by combination of the two different intermediate trench lengths l = 0.25 m and l = 0.55 m.

Shoring width (for HEB 180 extension bars)

Extension bar length [m]	b _c [m]	b [m]
0.000	0.780–1.220	0.980–1.420
0.275	1.055–1.495	1.255–1.695
0.550	1.330–1.770	1.530–1.970
1.100	1.880–2.320	2.080–2.520
1.650	2.430–2.870	2.630–3.070
2.200	2.980–3.420	3.180–3.620
2.200 + 1.100	4.080–4.520	4.280–4.720

Dimensions "from-to" depending on spindle stroke. Other trench widths possible by combination of different extension bar lengths.

l	Length	A	Surface
l _c	Pipe culvert length	G	Weight
b	Trench width	G / VP	Weight / shoring panel
b _c	Clear width	G / Box	Weight / shoring box
h _c	Pipe culvert height	eh	Admissible soil pressure
t _{pl}	Panel thickness		

KRINGS KS 100



General data

Shoring length	2.00 m–4.50 m
Base unit height	2.40 m / 2.60 m
Top unit height	1.30 m
Pipe culvert height	1.52 m / 1.56 m
Base box weight	1,414 kg–2,730 kg
Shoring width	variable

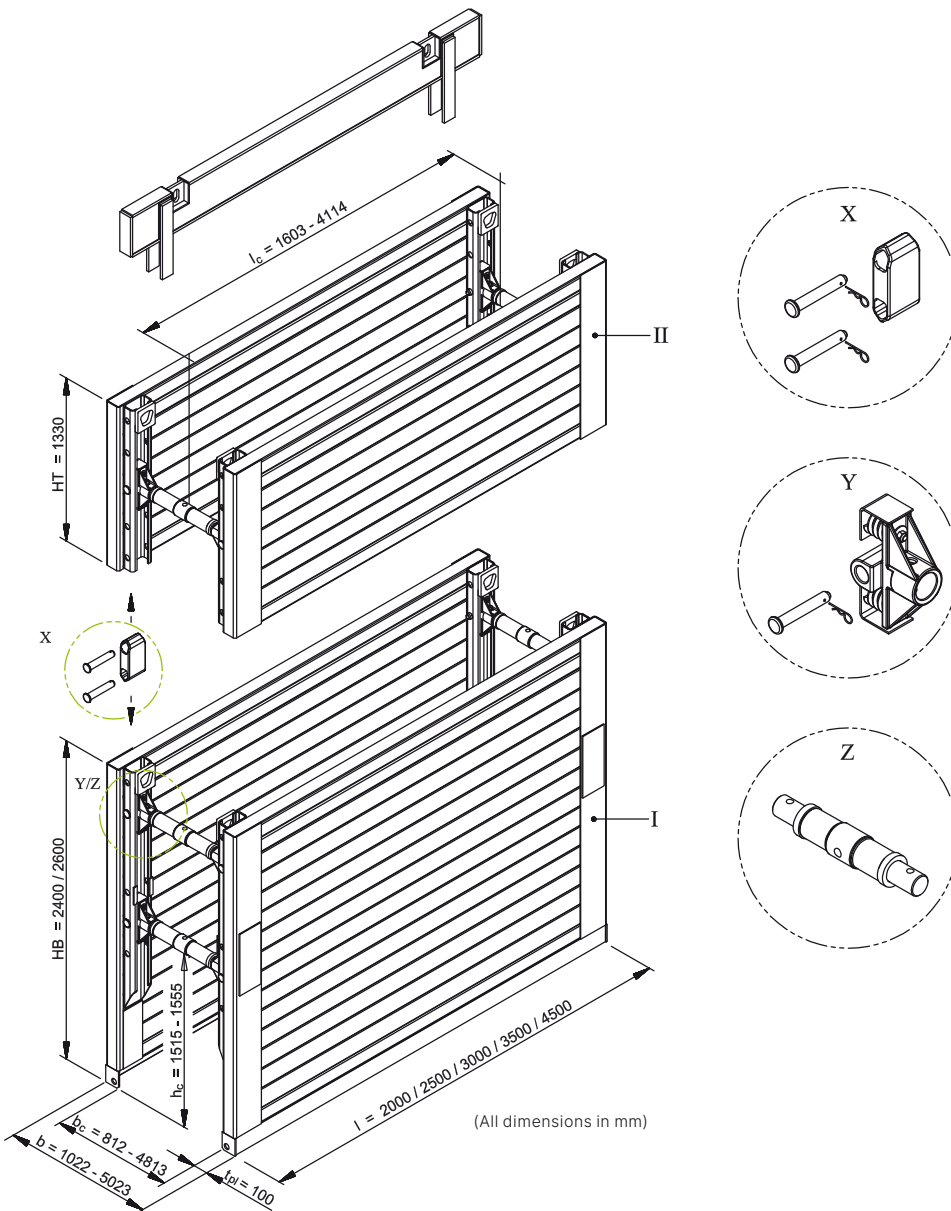

- | | | | | | | | |
|----|------------------|-------|----------------------|----------|--------------------------|---|--------------------------|
| I | Base unit | l | Length | h_c | Pipe culvert height | Z | Spindle 98 x ... |
| II | Top unit | l_c | Pipe culvert length | t_{pl} | Panel thickness | X | Connector with bolts |
| HB | Base unit height | b | Shoring/trench width | X | Connector with bolts | Y | Spring socket with bolts |
| HT | Top unit height | b_c | Clear width | Y | Spring socket with bolts | | |

Base units

Art. no.	l [m]	h [m]	t _{pl} [m]	h _c [m]	l _c [m]	G / VP [kg]	G / Box [kg]	A [m ²]	eh [kN/m ²]
132 030	2.00	2.40	0.10	1.52	1.61	567.0	1,414.0 *	4.80	60.0
132 050	2.50	2.40	0.10	1.52	2.11	675.0	1,630.0 *	6.00	57.0
132 070	3.00	2.40	0.10	1.52	2.61	761.0	1,802.0 *	7.20	48.0
132 090	3.50	2.40	0.10	1.52	3.11	830.0	1,940.0 *	8.40	44.0
132 140	4.00	2.40	0.10	1.52	3.61	1,000.0	2,280.0 *	9.60	40.0
132 156	4.50	2.40	0.10	1.52	4.11	1,120.0	2,520.0 *	10.80	31.8
132 040	2.00	2.60	0.10	1.56	1.61	612.0	1,504.0 *	5.20	55.0
132 060	2.50	2.60	0.10	1.56	2.11	711.0	1,702.0 *	6.50	52.0
132 080	3.00	2.60	0.10	1.56	2.61	813.0	1,906.0 *	7.80	44.0
132 100	3.50	2.60	0.10	1.56	3.11	905.0	2,090.0 *	9.10	44.0
132 150	4.00	2.60	0.10	1.56	3.61	1,090.0	2,460.0 *	10.40	40.0
132 121	4.50	2.60	0.10	1.56	4.11	1,225.0	2,730.0 *	11.70	31.8

* With spindle 98 × 700

Top units

Art. no.	l [m]	h [m]	t _{pl} [m]	h _c [m]	l _c [m]	G / VP [kg]	G / Box [kg]	A [m ²]	eh [kN/m ²]
132 190	2.00	1.30	0.10	-	1.61	370.0	922.0 *	2.60	60.0
132 200	2.50	1.30	0.10	-	2.11	430.0	1,042.0 *	3.25	57.0
132 210	3.00	1.30	0.10	-	2.61	486.0	1,154.0 *	3.90	48.0
132 220	3.50	1.30	0.10	-	3.11	570.0	1,322.0 *	4.55	44.0
132 260	4.00	1.30	0.10	-	3.61	660.0	1,502.0 *	5.20	40.0
132 261	4.50	1.30	0.10	-	4.11	730.0	1,642.0 *	5.85	31.8

* With spindle 98 × 700

Shoring widths for spindle 98 × 550

Extension bar	l [m]	b _c [m]	b [m]
	w/o	0.812–1.012	1.022–1.222
139 430	0.30	1.112–1.312	1.322–1.522
139 445	0.50	1.312–1.512	1.522–1.722
139 385	1.00	1.812–2.012	2.022–2.222
139 400	1.50	2.313–2.512	2.522–2.722
139 420	2.00	2.812–3.012	3.022–3.222
139 425	2.50	3.312–3.512	3.522–3.722

Shoring widths for spindle 98 × 700

Extension bar	l [m]	b _c [m]	b [m]
	w/o	0.988–1.328	1.198–1.538
139 430	0.30	1.288–1.628	1.498–1.838
139 445	0.50	1.488–1.828	1.698–2.038
139 385	1.00	1.988–2.328	2.198–2.538
139 400	1.50	2.488–2.828	2.698–3.038
139 420	2.00	2.988–3.328	3.198–3.538
139 425	2.50	3.488–3.828	3.698–4.038

Shoring widths for spindle 98 × 817

Number of extension bars	l [m]	b _c [m]	b [m]
0	0.00	0.913–1.313	1.123–1.523
1	0.50	1.413–1.813	1.623–2.023
2	1.00	1.913–2.313	2.123–2.523
3	1.50	2.413–2.813	2.623–3.023
4	2.00	2.913–3.313	3.123–3.523
5	2.50	3.413–3.813	3.623–4.023
6	3.00	3.913–4.313	4.123–4.523
7	3.50	4.413–4.813	4.623–5.023

Depending on the shoring strut, up to 7 extension bars of 500 mm each may be used.

l	Length	G / VP	Weight / shoring panel
A	Surface	G / Box	Weight / shoring box
h	Height	eh	Admissible soil pressure
b _c	Clear width	t _{pl}	Panel thickness
b	Trench width	h _c	Pipe culvert height
l _c	Pipe culvert length		

KRINGS KS 100 Manhole



General data

Shoring length	2.00 m–4.00 m
Base unit height	2.40 m / 2.60 m
Top unit height	1.40 m
Pipe culvert height	1.50 m / 1.56 m
Base box weight	1,814 kg–2,960 kg
Shoring width	variable

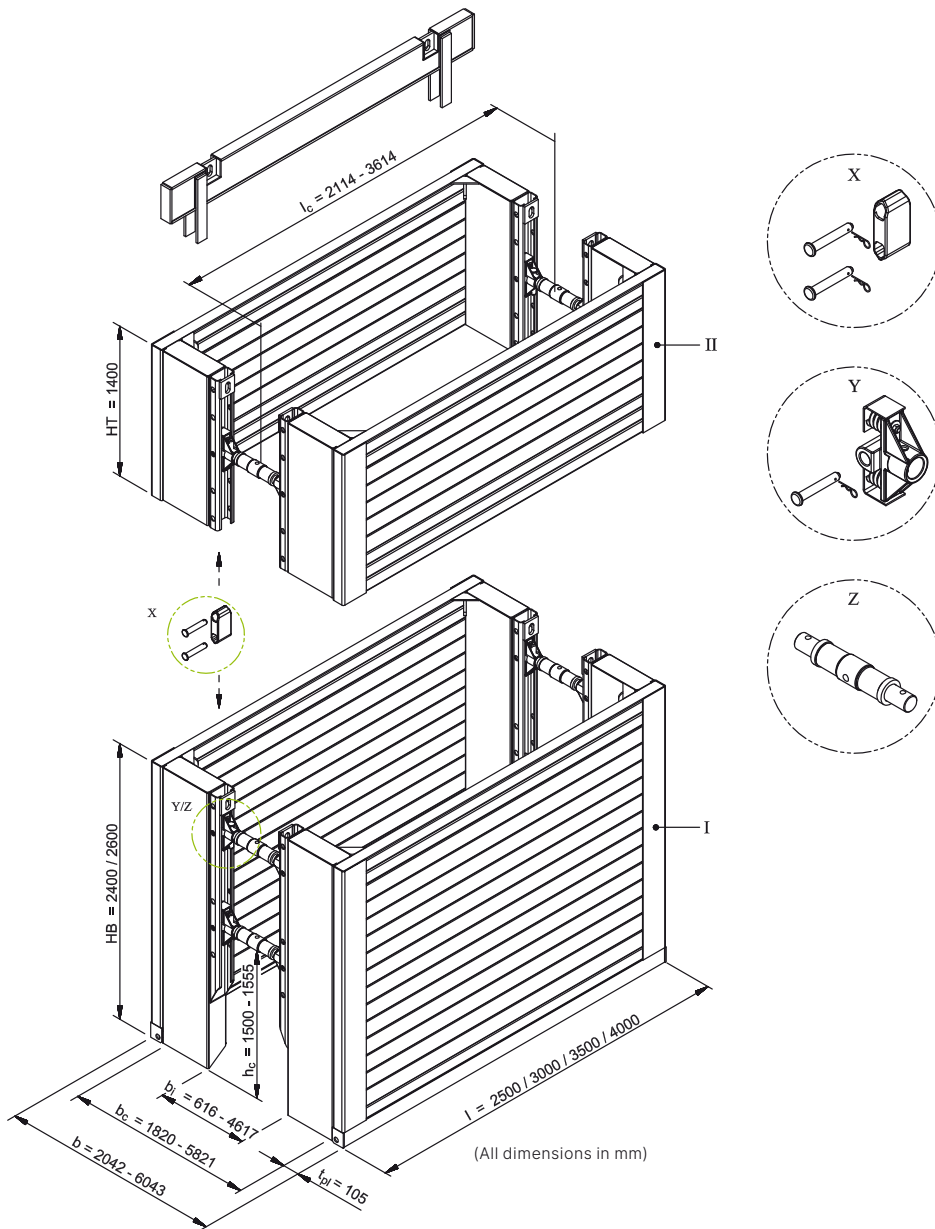

I	Base unit	I	Length	b _i	Clear passage width	X	Connector with bolts
II	Top unit	l _c	Pipe culvert length	h _c	Pipe culvert height	Y	Spring socket with bolts
HB	Base unit height	b	Shoring/trench width	t _{pl}	Panel thickness	Z	Spindle 98 x ...
HT	Top unit height	b _c	Clear width				

Base units

Art. no.	l [m]	h [m]	t _{pl} [m]	h _c [m]	l _c [m]	G / VP [kg]	G / Box [kg]	A [m ²]	eh [kN/m ²]
135 118	2.00	2.40	0.105	1.50	1.61	767.0	1,814.0 *	4.80	60.0
135 099	2.50	2.40	0.105	1.50	2.11	860.0	2,000.0 *	6.00	57.0
135 109	3.00	2.40	0.105	1.50	2.61	961.0	2,202.0 *	7.20	48.0
135 120	3.50	2.40	0.105	1.50	3.11	1,060.0	2,400.0 *	8.40	44.0
135 121	4.00	2.40	0.105	1.50	3.61	1,225.0	2,730.0 *	9.60	40.0
135 122	4.50	2.40	0.105	1.50	4.11	1,360.0	3,000.0 *	10.80	31.8
135 095	2.00	2.60	0.105	1.56	1.61	840.0	1,960.0 *	5.20	55.0
135 100	2.50	2.60	0.105	1.56	2.11	950.0	2,180.0 *	6.50	52.0
135 110	3.00	2.60	0.105	1.56	2.61	1,041.0	2,362.0 *	7.80	44.0
135 130	3.50	2.60	0.105	1.56	3.11	1,160.0	2,600.0 *	9.10	44.0
135 140	4.00	2.60	0.105	1.56	3.61	1,340.0	2,960.0 *	10.40	40.0

* With spindle 98 × 700

Top units

Art. no.	l [m]	h [m]	t _{pl} [m]	h _c [m]	l _c [m]	G / VP [kg]	G / Box [kg]	A [m ²]	eh [kN/m ²]
135 239	2.00	1.40	0.105	-	1.61	590.0	1,362.0 *	2.80	60.0
135 240	2.50	1.40	0.105	-	3.61	655.0	1,492.0 *	3.50	61.6
135 250	3.00	1.40	0.105	-	3.61	720.0	1,622.0 *	4.20	51.3
135 260	3.50	1.40	0.105	-	3.61	831.0	1,844.0 *	4.90	44.1
135 270	4.00	1.40	0.105	-	3.61	940.0	2,062.0 *	5.60	33.0

* With spindle 98 × 700

Shoring widths for spindle 98 × 550

Extension bar	l [m]	b _i [m]	b _c [m]	b [m]
	w/o	0.616–0.816	1.820–2.020	2.042–2.242
139 430	0.30	0.916–1.116	2.120–2.320	2.342–2.542
139 445	0.50	1.116–1.316	2.320–2.520	2.542–2.742
139 385	1.00	1.616–1.816	2.820–3.020	3.042–3.242
139 400	1.50	2.116–2.316	3.320–3.520	3.542–3.742
139 420	2.00	2.616–2.816	3.820–4.020	4.042–4.242
139 425	2.50	3.116–3.316	4.320–4.520	4.542–4.742

Shoring widths for spindle 98 × 700

Extension bar	l [m]	b _i [m]	b _c [m]	b [m]
	w/o	0.792–1.132	1.996–2.336	2.218–2.558
139 430	0.30	1.092–1.432	2.296–2.636	2.518–2.858
139 445	0.50	1.292–1.632	2.496–2.836	2.718–3.058
139 385	1.00	1.792–2.132	2.996–3.336	3.218–3.558
139 400	1.50	2.292–2.632	3.496–3.836	3.718–4.058
139 420	2.00	2.792–3.132	3.996–4.336	4.218–4.558
139 425	2.50	3.292–3.632	4.496–4.836	4.718–5.058

Shoring widths for spindle 98 × 817

Number of extension bars	l [m]	b _i [m]	b _c [m]	b [m]
0	0.00	0.717–1.117	1.921–2.321	2.143–2.543
1	0.50	1.217–1.617	2.421–2.821	2.643–3.043
2	1.00	1.717–2.117	2.921–3.321	3.143–3.543
3	1.50	2.217–2.617	3.421–3.821	3.643–4.043
4	2.00	2.717–3.117	3.921–4.321	4.143–4.543
5	2.50	3.217–3.617	4.421–4.821	4.643–5.043
6	3.00	3.717–4.117	4.921–5.321	5.143–5.543
7	3.50	4.217–4.617	5.421–5.821	5.643–6.043

Depending on the shoring strut, up to 7 extension bars of 500 mm each may be used.

l	Length	h _c	Pipe culvert height
l _c	Pipe culvert length	t _{pl}	Panel thickness
b	Trench width	A	Surface
b _i	Clear passage width	G / VP	Weight / shoring panel
b _c	Clear width	G / Box	Weight / shoring box
h	Panel height	eh	Admissible soil pressure

E+S Manhole



General data

Shoring length	2.50 m–3.50 m
Base unit height	2.50 m
Top unit height	1.50 m
Pipe culvert height	1.45 m
Base box weight	2,260 kg–2,710 kg
Shoring width	variable

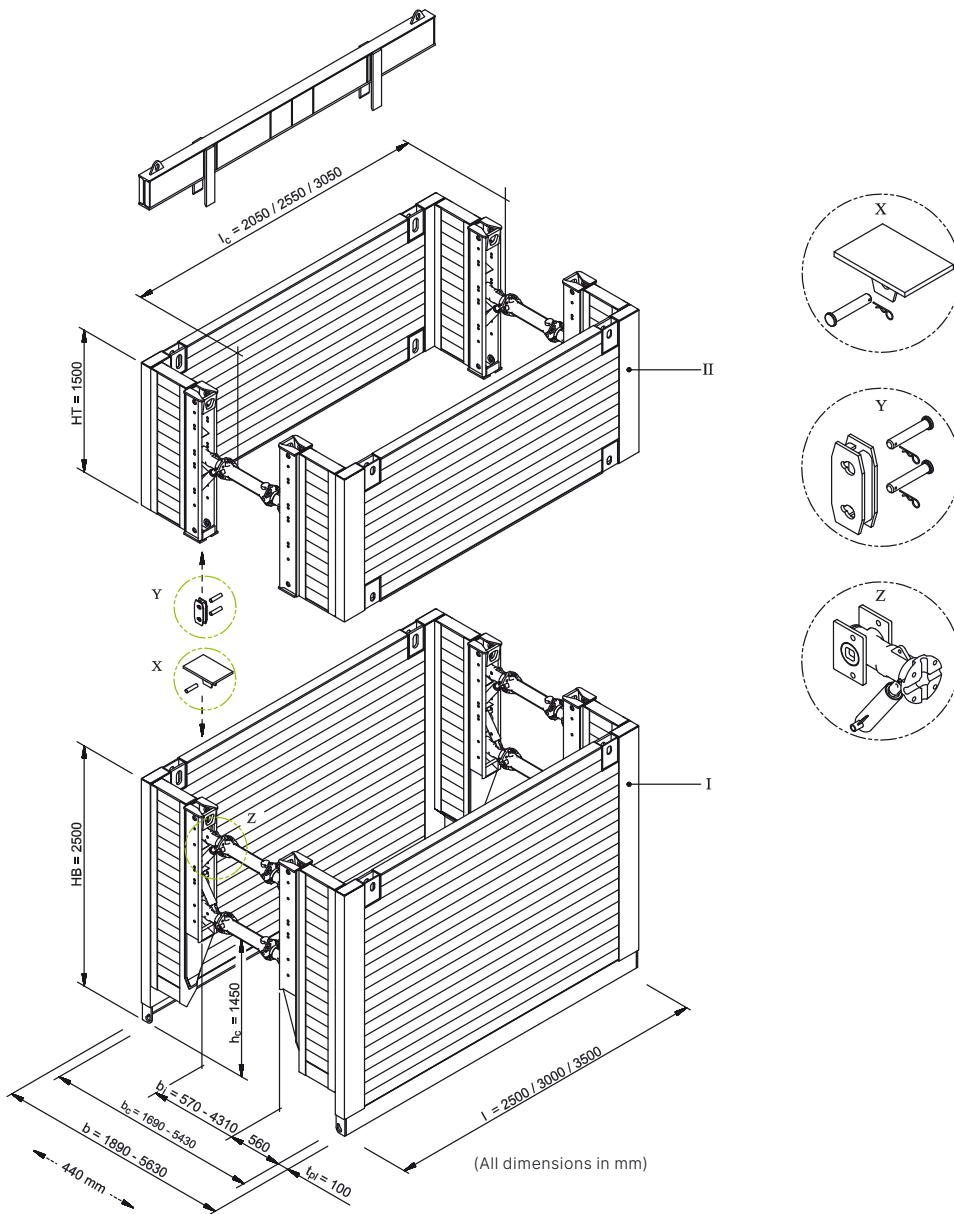

- | | | | | | | | |
|----|------------------|-------|----------------------|----------|---------------------------|---|---|
| I | Base unit | l | Length | b_i | Clear passage width | Y | Connector with bolts |
| II | Top unit | l_c | Pipe culvert length | h_c | Pipe culvert height | Z | Strut with bearing panel and stabilizer |
| HB | Base unit height | b | Shoring/trench width | t_{pl} | Panel thickness | X | Pressure panel with bolts |
| HT | Top unit height | b_c | Clear width | X | Pressure panel with bolts | | |

Base units (height 2.50 m)

Art. no.	l [m]	t _{pl} [m]	h _c [m]	l _c [m]	G / VP [kg]	G / Box [kg]	Surface A [m ²]	eh [kN/m ²]
828 005	2.50	0.10	1.45	2.05	1,130.0	2,260.0	6.25	81.8
828 015	3.00	0.10	1.45	2.55	1,275.0	2,550.0	7.50	67.4
828 025	3.50	0.10	1.45	3.05	1,355.0	2,710.0	8.75	47.7

Top units (height 1.50 m)

Art. no.	l [m]	t _{pl} [m]	h _c [m]	l _c [m]	G / VP [kg]	G / Box [kg]	Surface A [m ²]	eh [kN/m ²]
829 005	2.50	0.10	-	2.05	944.0	1,888.0	3.75	90.9
829 015	3.00	0.10	-	2.55	1,015.0	2,030.0	4.50	67.4
829 025	3.50	0.10	-	3.05	1,090.0	2,180.0	5.25	47.7

Extension bars

Art. no.	Short description	l [m]	G [kg]
850 091	Cast extension bar	0.250	11.2
850 100	Cast extension bar	0.550	18.7
850 112	HEB 180 extension bar	0.275	28.0
850 110	HEB 180 extension bar	0.550	43.0
850 124	HEB 180 extension bar	1.100	70.0
850 132	HEB 180 extension bar	1.650	100.0
850 135	HEB 180 extension bar	2.200	130.0

Shoring widths (for cast pipe extension bars, l = 0.55 m)

Extension bars	Extension bar length [m]	b _c [m]	b _i [m]	b [m]
0	0.00	1.69–2.13	0.57–1.01	1.89–2.33
1	0.55	2.24–2.68	1.12–1.56	2.44–2.88
2	1.10	2.79–3.23	1.67–2.11	2.99–3.43
3	1.65	3.34–3.78	2.22–2.66	3.54–3.98
4	2.20	3.89–4.33	2.77–3.21	4.09–4.53
5	2.75	4.44–4.88	3.32–3.76	4.64–5.08
max. 6	3.30	4.99–5.43	3.87–4.31	5.19–5.63

Dimensions "from-to" depending on spindle stroke. Other trench widths possible by combination of the two different intermediate trench lengths l = 0.25 m and l = 0.55 m.

Shoring widths (for HEB 180 extension bars)

Extension bar length [m]	b _c [m]	b _i [m]	b [m]
0.000	1.690–2.130	0.570–1.010	1.890–2.330
0.275	1.965–2.405	0.845–1.285	2.165–2.605
0.550	2.240–2.680	1.120–1.560	2.440–2.880
1.100	2.790–3.230	1.670–2.110	2.990–3.430
1.650	3.340–3.780	2.220–2.660	3.540–3.980
2.200	3.890–4.330	2.770–3.210	4.090–4.530
2.200 + 1.100	4.990–5.430	3.870–4.310	5.190–5.630

Dimensions "from-to" depending on spindle stroke. Other trench widths possible by combination of different extension bar lengths.

l	Length	b _c	Clear width	A	Surface	G / Box	Weight / shoring box
l _c	Pipe culvert length	h _c	Pipe culvert height	G / VP	Weight / shoring panel	eh	Admissible soil pressure
b	Trench width	t _{pl}	Panel thickness	b _i	Clear passage width		

E+S Linear box



General data

Shoring length	3.40 m–4.50 m
Base unit height	3.00 m
Top unit height	1.32 m / 2.00 m
Pipe culvert height	variable
Base box weight	2,050 kg–2,940 kg
Shoring width	variable

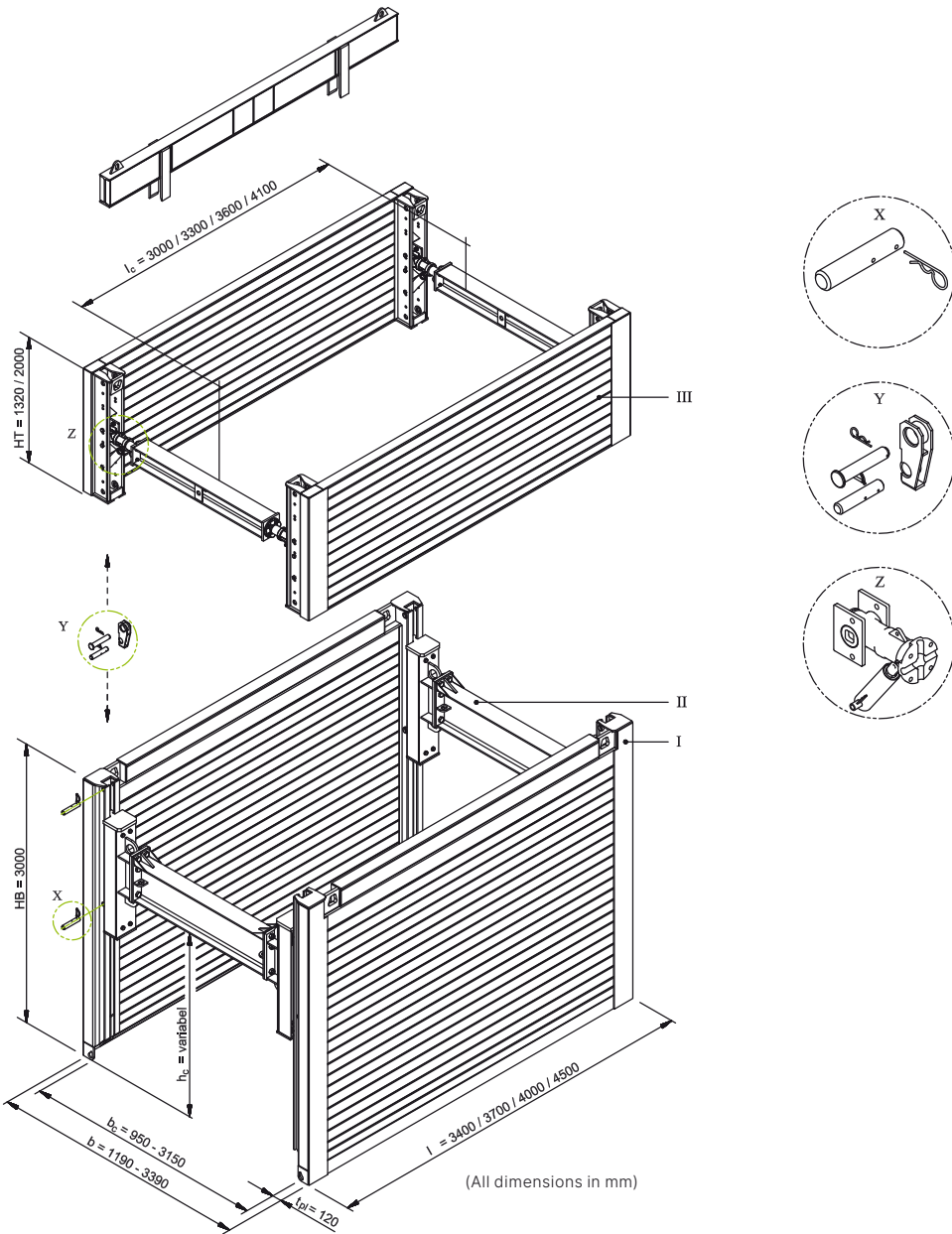

- | | | | | | | | |
|-----|-----------------------------------|----------------|----------------------|-----------------|---------------------|---|---|
| I | Base unit | HT | Top unit height | b _c | Clear width | Y | Connector with bolts |
| II | Linear box strut cart (base unit) | l | Length | h _c | Pipe culvert height | Z | Strut with bearing panel and stabilizer |
| III | Top unit, see Magnum/Medium | l _c | Pipe culvert length | t _{pl} | Panel thickness | | |
| HB | Base unit height | b | Shoring/trench width | X | Positioning bolt | | |

Strut cart

Art. no.	Short description	l [m]	G [kg]
832 226	Linear box U-strut cart (base unit)	1.38	200.0
832 232	Linear box U-strut cart, reinforced, (base unit)	1.20	217.0

Base units with strut cart

Art. no.	l [m]	h [m]	t _{pl} [m]	h _c [m]	l _c [m]	G / VP [kg]	G / Box [kg]	A [m ²]	eh [kN/m ²]
802 328	3.40	3.00	0.10	variable	3.00	1,025.0	2,050.0	10.20	48.2
802 321	3.70	3.00	0.10	variable	3.30	1,089.0	2,178.0	11.10	40.9
802 323	4.00	3.00	0.10	variable	3.60	1,255.0	2,510.0	12.00	35.2
802 325	4.50	3.00	0.10	variable	4.10	1,470.0	2,940.0	13.50	27.4

Base units, reinforced

Art. no.	l [m]	h [m]	t _{pl} [m]	h _c [m]	l _c [m]	G / VP [kg]	G / Box [kg]	A [m ²]	eh [kN/m ²]
802 340	3.70	3.00	0.12	variable	3.30	1,553.0	4,001.0	11.1	66.0
802 337	4.00	3.00	0.12	variable	3.60	1,643.0	4,181.0	12.0	56.0
802 386	4.50	3.00	0.12	variable	4.10	1,815.0	4,525.0	13.5	44.0

Top units with struts

Art. no.	l [m]	h [m]	t _{pl} [m]	h _c [m]	l _c [m]	G / VP [kg]	G / Box [kg]	A [m ²]	eh [kN/m ²]
800 700	3.40	1.32	0.10	-	2.95	658.0	1,316.0	4.49	50.5
802 700	3.40	2.00	0.10	-	2.95	930.0	1,860.0	6.80	50.5
800 800	3.70	1.32	0.10	-	3.25	692.0	1,384.0	4.88	42.1
802 750	3.70	2.00	0.10	-	3.25	990.0	1,980.0	7.40	42.1
800 900	4.00	1.32	0.10	-	3.55	775.0	1,550.0	5.28	43.8
800 950	4.50	1.32	0.10	-	4.05	820.0	1,640.0	5.94	34.2

Extension bars

Art. no.	Short description	l [m]	G [kg]
831 030	IPE 400 extension bar	0.275	57.0
831 040	IPE 400 extension bar	0.550	75.0
831 050	IPE 400 extension bar	1.100	115.0
831 060	IPE 400 extension bar	1.650	155.0
831 070	IPE 400 extension bar	2.200	195.0

Shoring widths (for IPE 400 extension bars)

Extension bar length [m]	b _c [m]	b [m]
0.000	0.95	1.15
0.275	1.23	1.43
0.550	1.50	1.70
1.100	2.05	2.25
1.650	2.60	2.80
2.200	3.15	3.35

Other trench widths possible by combination of different extension bar lengths.

l	Length	b _c	Clear width	t _{pl}	Panel thickness	G / Box	Weight / shoring box
l _c	Pipe culvert length	h	Panel height	A	Surface	eh	Admissible soil pressure
b	Trench width	h _c	Pipe culvert height	G / VP	Weight / shoring panel		

E+S Magnum shoring



General data

Shoring length	2.00 m–6.84 m
Base unit height	3.00 m / 3.15 m / 4.00 m
Top unit height	1.32 m / 1.44 m / 2.00 m
Pipe culvert height	1.75 m / 2.01 m / 2.46 m
Base box weight	1,760 kg–7,130 kg
Shoring width	variable

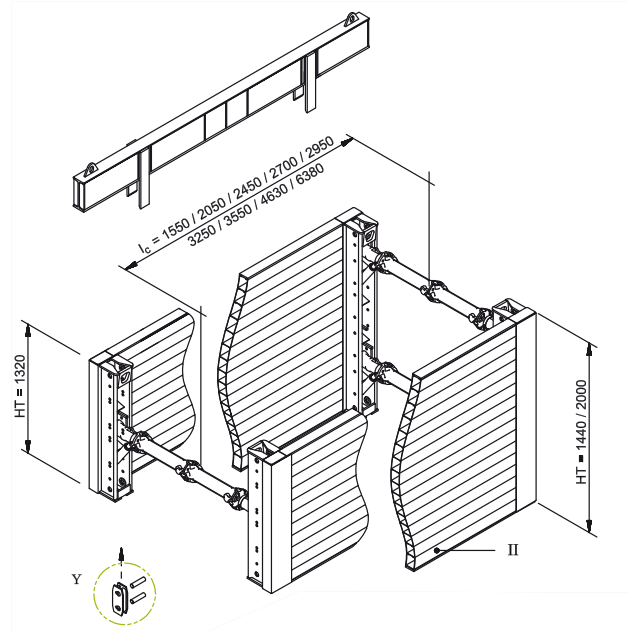
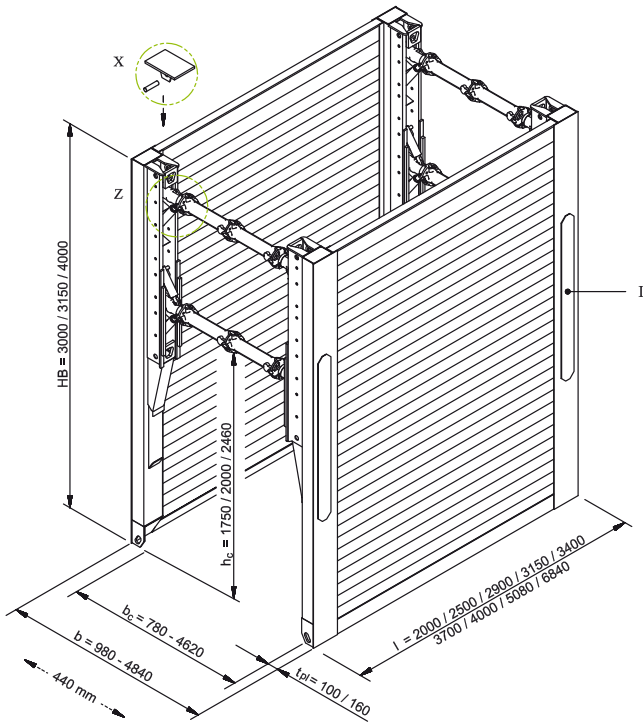

(All dimensions in mm)

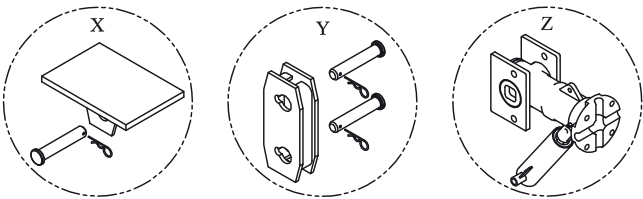

- | | | | | | | | |
|----|------------------|-------|----------------------|----------|---------------------------|---|---|
| I | Base unit | l | Length | h_c | Pipe culvert height | Z | Strut with bearing panel and stabilizer |
| II | Top unit | l_c | Pipe culvert length | t_{pl} | Panel thickness | | |
| HB | Base unit height | b | Shoring/trench width | X | Pressure panel with bolts | | |
| HT | Top unit height | b_c | Clear width | Y | Connector with bolts | | |

Base units (height 3.00 m)

Art. no.	l [m]	t _{pl} [m]	h _c [m]	l _c [m]	G / VP [kg]	G / Box [kg]	A [m ²]	eh [kN/m ²]
802 035	2.00	0.10	2.01	1.55	880.0	1,760.0	6.00	69.5
802 042	2.50	0.10	2.01	2.05	990.0	1,980.0	7.50	55.7
802 045	2.90	0.10	2.01	2.45	1,080.0	2,160.0	8.70	48.0
802 120	3.40	0.10	2.01	2.95	1,185.0	2,370.0	10.20	41.0
802 205	3.70	0.10	2.01	3.25	1,255.0	2,510.0	11.10	37.7
802 285 A	4.00	0.10	2.01	3.55	1,410.0	2,820.0	12.00	35.8
802 400	5.08	0.12	2.01	4.63	1,868.0	3,736.0	15.24	28.6
802 450	6.84	0.16	1.75	6.38	3,465.0	6,930.0	20.52	25.8

Base units (height 3.15 m)

Art. no.	l [m]	t _{pl} [m]	h _c [m]	l _c [m]	G / VP [kg]	G / Box [kg]	A [m ²]	eh [kN/m ²]
802 036	2.00	0.10	2.01	1.55	930.0	1,860.0	6.00	73.1
802 040	2.50	0.10	2.01	2.05	1,042.0	2,084.0	7.50	58.5
802 050	2.90	0.10	2.01	2.45	1,138.0	2,276.0	8.70	50.4
802 175	3.40	0.10	2.01	2.95	1,260.0	2,520.0	10.20	43.0
802 210	3.70	0.10	2.01	3.25	1,428.0	2,856.0	11.10	39.5
802 300	4.00	0.10	2.01	3.55	1,579.0	3,158.0	12.00	36.5
802 425	5.08	0.12	2.01	4.63	1,918.0	3,836.0	15.24	28.6
802 460	6.84	0.16	1.75	6.38	3,565.0	7,130.0	21.55	25.8

Base units (height 4.00 m)

Art. no.	l [m]	t _{pl} [m]	h _c [m]	l _c [m]	G / VP [kg]	G / Box [kg]	A [m ²]	eh [kN/m ²]
802 100	3.15	0.08	2.46	2.70	1,405.0	2,810.0	12.60	46.0
802 197 A	3.40	0.09	2.46	2.95	1,740.0	3,480.0	13.60	41.0

Top units (height 1.32 m)

Art. no.	l [m]	t _{pl} [m]	h _c [m]	l _c [m]	G / VP [kg]	G / Box [kg]	A [m ²]	eh [kN/m ²]
800 550	2.00	0.10	-	1.55	463.0	926.0	2.64	165.0
800 600	2.50	0.10	-	2.05	531.0	1,062.0	3.30	99.3
800 650	2.90	0.10	-	2.45	578.0	1,156.0	3.83	71.5
802 560	3.15	0.08	-	2.70	670.0	1,340.0	4.16	60.7
800 700	3.40	0.10	-	2.95	658.0	1,316.0	4.49	50.5
800 800	3.70	0.10	-	3.25	692.0	1,384.0	4.88	42.1
800 900	4.00	0.10	-	3.55	775.0	1,550.0	5.28	43.8
802 814	5.08	0.12	-	4.63	1,118.0	2,236.0	6.71	34.2

Top units (height 1.44 m)

Art. no.	l [m]	t _{pl} [m]	h _c [m]	l _c [m]	G / VP [kg]	G / Box [kg]	A [m ²]	eh [kN/m ²]
802 815	6.84	0.16	-	6.38	1,505.0	3,010.0	9.85	25.8

l	Length	h _c	Pipe culvert height	b	Trench width	l _c	Pipe culvert length
t _{pl}	Panel thickness	G / VP	Weight / shoring panel	A	Surface	eh	Admissible soil pressure
G / Box	Weight / shoring box	b _c	Clear width				

Top units (height 2.00 m)

Art. no.	l [m]	t _{pl} [m]	h _c [m]	l _c [m]	G / VP [kg]	G / Box [kg]	A [m ²]	eh [kN/m ²]
802 680	2.00	0.10	-	1.55	697.0	1,394.0	4.00	165.0
802 690	2.50	0.10	-	2.05	785.0	1,570.0	5.00	99.3
802 550	2.90	0.10	-	2.45	840.0	1,680.0	5.80	71.5
802 600	3.15	0.08	-	2.70	860.0	1,720.0	6.30	60.7
802 700	3.40	0.10	-	2.95	930.0	1,860.0	6.80	50.5
802 750	3.70	0.10	-	3.25	990.0	1,980.0	7.40	42.1
802 751	4.00	0.10	-	3.55	1,085.0	2,170.0	8.00	43.8

Extension bars

Art. no.	Short description	l [m]	G [kg]
850 091	Cast extension bar	0.250	11.2
850 100	Cast extension bar	0.550	18.7
850 112	HEB 180 extension bar	0.275	28.0
850 110	HEB 180 extension bar	0.550	43.0
850 124	HEB 180 extension bar	1.100	70.0
850 132	HEB 180 extension bar	1.650	100.0
850 135	HEB 180 extension bar	2.200	130.0

Shoring widths (for cast pipe extension bars, l = 0.55 m)

		for base unit h = 3.15 m				for base unit h = 4.00 m			
		Element l = 4.00 m		Element l = 5.08 m	Element l = 6.84 m	Element l = 3.15 m		Element l = 3.40 m	
Extension bars	Extension bar length [m]	b _c [m]	b [m]	b [m]	b [m]	b _c [m]	b [m]	b [m]	
0	0.00	0.78–1.22	0.98–1.42	1.02–1.46	1.10–1.54	0.88–1.32	1.04–1.48	1.08–1.52	
1	0.55	1.33–1.77	1.53–1.97	1.57–2.01	1.65–2.09	1.43–1.87	1.59–2.03	1.63–2.07	
2	1.10	1.88–2.32	2.08–2.52	2.12–2.56	2.20–2.64	1.98–2.42	2.14–2.58	2.18–2.62	
3	1.65	2.43–2.87	2.63–3.07	2.67–3.11	2.75–3.19	2.53–2.97	2.69–3.13	2.73–3.17	
4	2.20	2.98–3.42	3.18–3.62	3.22–3.66	3.30–3.74	3.08–3.52	3.24–3.68	3.28–3.72	
5	2.75	3.53–3.97	3.73–4.17	3.77–4.21	3.85–4.29	3.63–4.07	3.79–4.23	3.83–4.27	
max. 6	3.30	4.08–4.52	4.28–4.72	4.32–4.76	4.40–4.84	4.18–4.62	4.34–4.78	4.38–4.82	

Dimensions "from-to" depending on spindle stroke. Other trench widths possible by combination of the two different intermediate trench lengths l = 0.25 m and l = 0.55 m.

Shoring widths (for HEB 180 extension bars)

		for base unit h = 3.15 m				for base unit h = 4.00 m			
		Element l = 4.00 m		Element l = 5.08 m	Element l = 6.84 m	Element l = 3.15 m		Element l = 3.40 m	
Extension bar length [m]	bc [m]	b [m]	b [m]	b [m]	b [m]	bc [m]	b [m]	b [m]	
0.000	0.78–1.22	0.98–1.42	1.02–1.46	1.10–1.54	0.88–1.32	1.04–1.48	1.08–1.52		
0.275	1.06–1.50	1.26–1.70	1.30–1.74	1.38–1.82	1.16–1.60	1.32–1.76	1.36–1.80		
0.550	1.33–1.77	1.53–1.97	1.57–2.01	1.65–2.09	1.43–1.87	1.59–2.03	1.63–2.07		
1.100	1.88–2.32	2.08–2.52	2.12–2.56	2.20–2.64	1.98–2.42	2.14–2.58	2.18–2.62		
1.650	2.43–2.87	2.63–3.07	2.67–3.11	2.75–3.19	2.53–2.97	2.69–3.13	2.73–3.17		
2.200	2.98–3.42	3.18–3.62	3.22–3.66	3.30–3.74	3.08–3.52	3.24–3.68	3.28–3.72		
2.200 + 1.100	4.08–4.52	4.28–4.72	4.32–4.76	4.40–4.84	4.18–4.62	4.34–4.78	4.38–4.82		

Dimensions "from-to" depending on spindle stroke. Other trench widths possible by combination of different extension bar lengths.

l	Length	h _c	Pipe culvert height	b	Trench width	l _c	Pipe culvert length
t _{pl}	Panel thickness	G / VP	Weight / shoring panel	A	Surface	eh	Admissible soil pressure
G / Box	Weight / shoring box	b _c	Clear width				

Box installation window

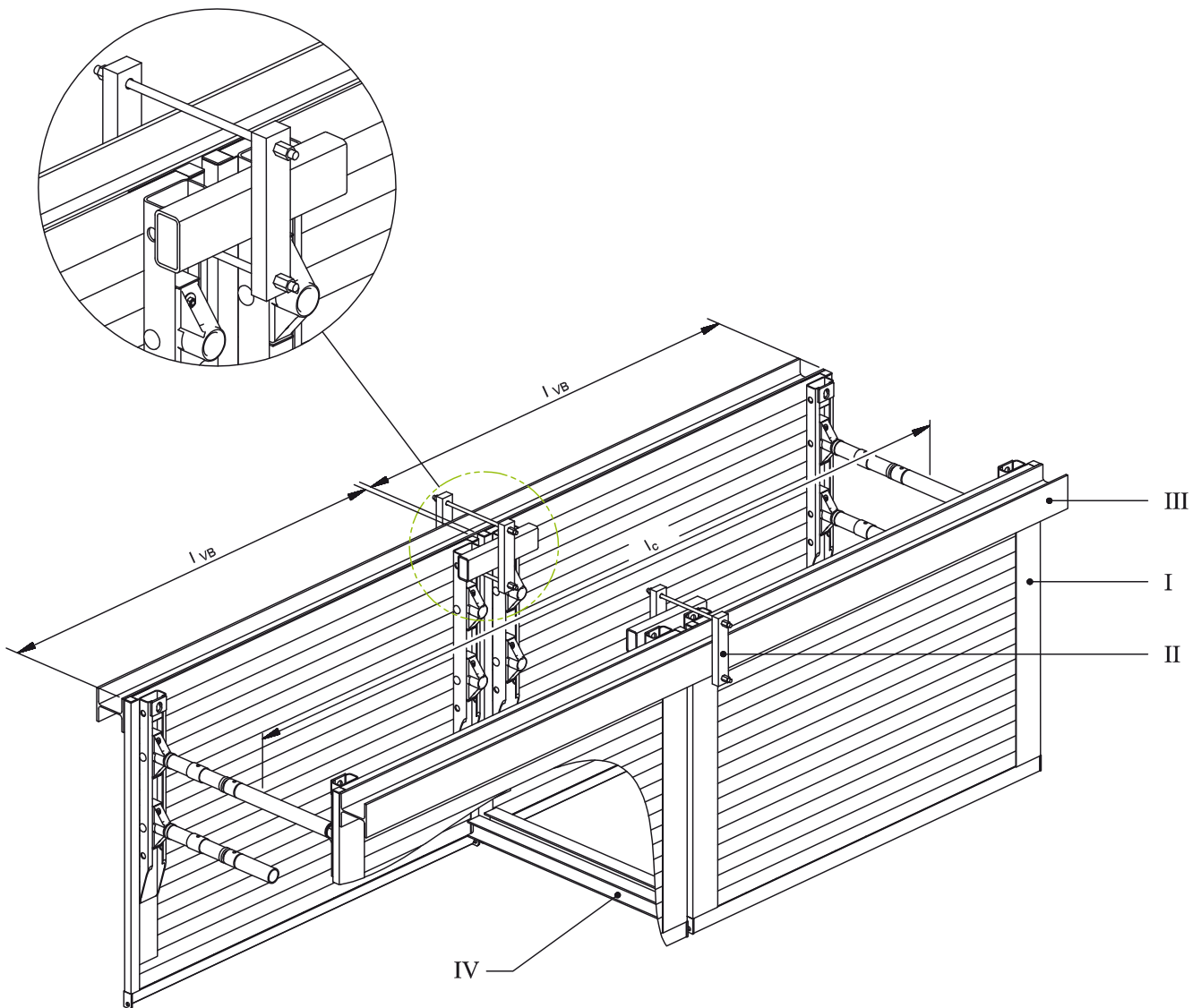

- I Shoring box
- II GEWI box waler soldier attachment

- III Waler soldier
- IV Soldier bottom end support

- IVB Length shoring box
- l_c Pipe culvert length

E+S Dragbox



General data

Shoring length	3.70 m–5.08 m
Base unit height	3.00 m / 3.15 m
Pipe culvert height	1.88 m / 2.00 m
Base box weight	3,140 kg–4,170 kg
Shoring width	variable

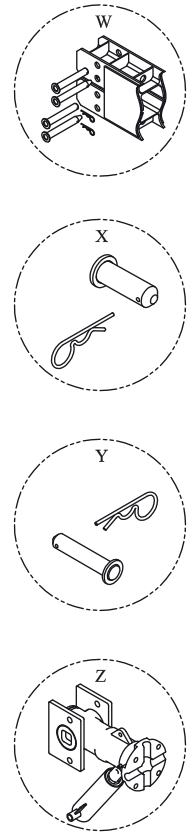
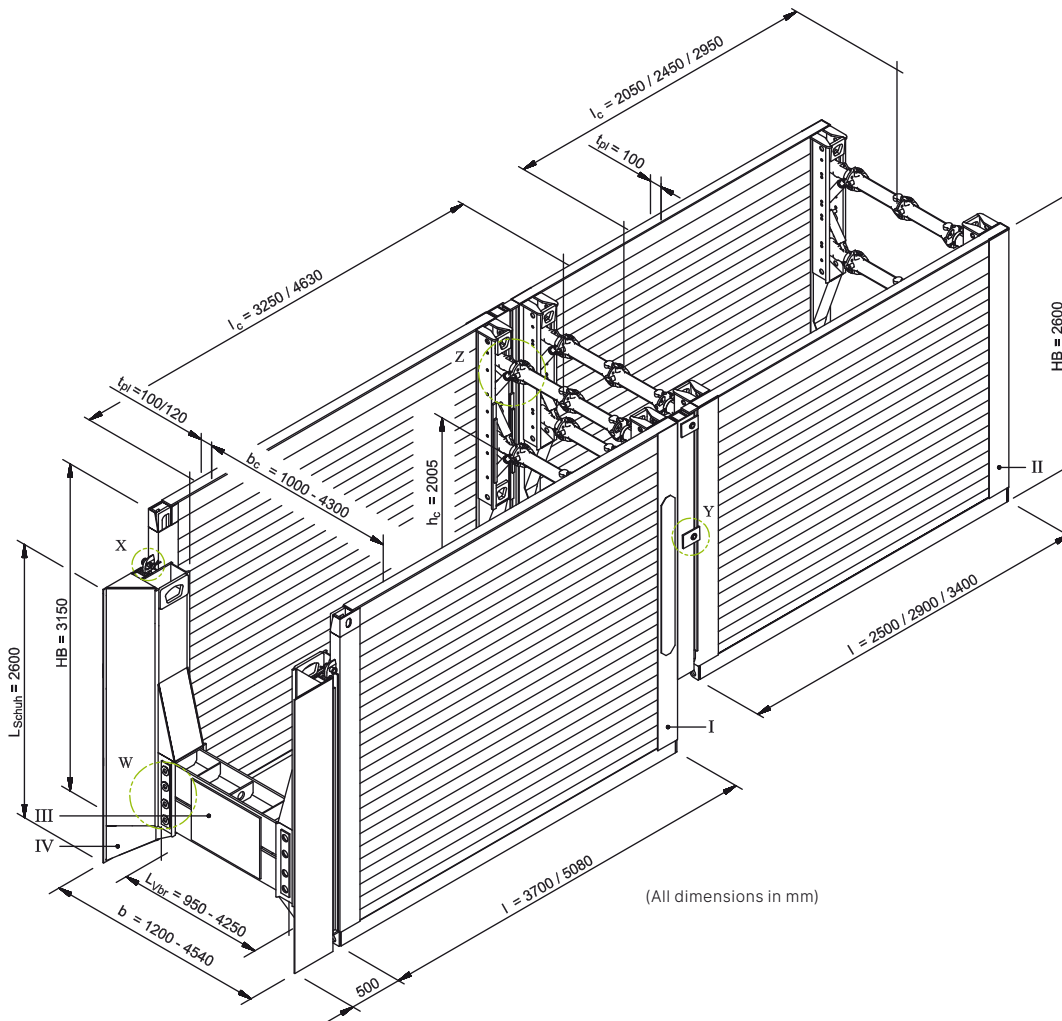

I	Dragbox base unit	L _{Vbr}	Connection bar length	b _c	Clear width	Y	Drag plate positioning bolt
II	Drag plate	L _{Schuh}	Cutting blade length	h _c	Pipe culvert height	Z	Strut with bearing panel and stabilizer
III	Connection bar	l	Length	t _{pl}	Panel thickness	W	Connection bar positioning bolt
IV	Cutting blade	l _c	Pipe culvert length	W	Connection bar positioning bolt	X	Cutting blade positioning bolts
HB	Base unit height	b	Shoring/trench width	X	Cutting blade positioning bolts		

Base units

Art. no.	l [m]	h [m]	t _{pl} [m]	h _c [m]	l _c [m]	G / VP [kg]	G / Box [kg]	A [m ²]	eh [kN/m ²]
802 269	3.70	3.15	0.10	2.00	3.25	1,570.00	3,140.00	11.66	39.5
802 411	5.08	3.00	0.12	1.88	4.63	2,085.00	4,170.00	15.24	28.6

Cutting blades

Art. no.	Short description	l [m]	G [kg]
847 100	Right cutting blade	0.65	580.0
847 150	Left cutting blade	0.65	580.0

Connection bars

Art. no.	Short description	l [m]	G [kg]
847 200	Connection bar	0.95	295.0
847 210	Connection bar	1.50	500.0
847 220	Connection bar	2.05	715.0
847 230	Connection bar	2.60	920.0
847 240	Connection bar	3.15	1,125.0
847 250	Connection bar	3.70	1,330.0
847 260	Connection bar	4.25	1,530.0

Bolts

Art. no.	Short description	l [m]	G [kg]	d [m]
847 300	Bolt (blunt)	0.385	10.0	0.06
847 301	Bolt (inclined)	0.445	11.0	0.06

Extension bars

Art. no.	Short description	l [m]	G [kg]
850 091	Cast extension bar	0.250	11.2
850 100	Cast extension bar	0.550	18.7
850 112	HEB 180 extension bar	0.275	28.0
850 110	HEB 180 extension bar	0.550	43.0
850 124	HEB 180 extension bar	1.100	70.0
850 132	HEB 180 extension bar	1.650	100.0
850 135	HEB 180 extension bar	2.200	130.0

Shoring widths (for cast pipe extension bars, l = 0.55 m and HEB 180)

Extension bar length [m]	Connection bar length [m]	b _c [m]	for base unit t _{pl} = 0.10 m		for base unit t _{pl} = 0.12 m	
			b [m]		b [m]	
0.00	0.95	1.00	1.20		1.24	
0.55	1.50	1.55	1.75		1.79	
1.10	2.05	2.10	2.30		2.34	
1.65	2.60	2.65	2.85		2.89	
2.20	3.15	3.20	3.40		3.44	
2.20 + 0.55	3.70	3.75	3.95		3.99	
2.20 + 1.10	4.25	4.30	4.50		4.54	

l	Length	h _c	Pipe culvert height	G / VP	Weight / shoring panel	h	Panel height
l _c	Pipe culvert length	t _{pl}	Panel thickness	G / Box	Weight / shoring box	G	Weight
b	Trench width	A	Surface	eh	Admissible soil pressure	d	Diameter
b _c	Clear width						

KRINGS BLU piling frame element



General data

Shoring length	2.41 m
Piling frame element height	0.72 m
Pipe culvert length	2.17 m
Shoring depth	max. 2.40 m
Box weight	473 kg
Shoring width	variable

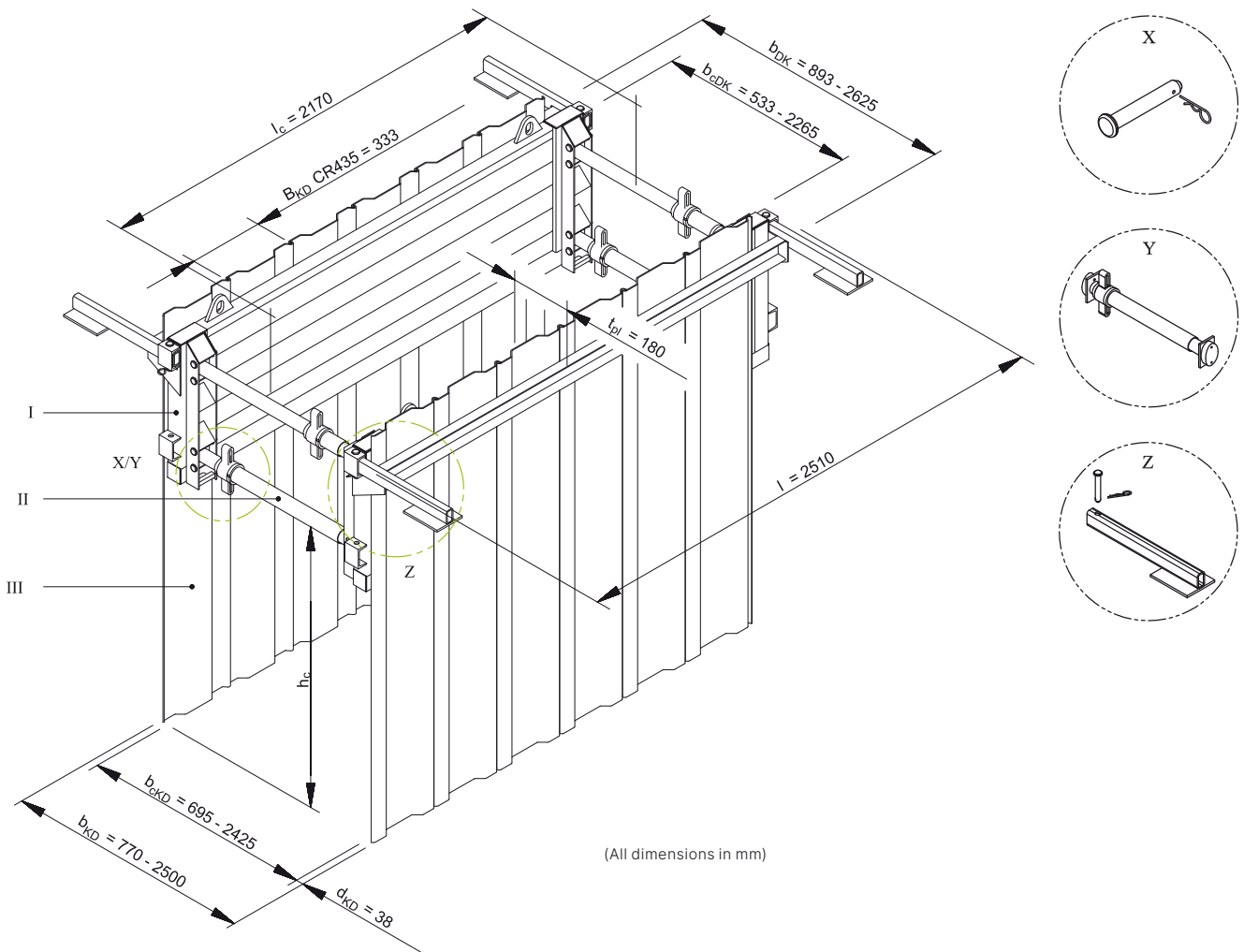

I	BLU piling frame element	d _{KD}	Sheet pile thickness	h _c	Pipe culvert height	b _{DK}	Piling frame shoring width
II	Spindle 70 × ...	t _{pl}	Panel thickness	b _{cKD}	Sheet pile clear width	X	Positioning bolt
III	Sheet pile	l	Length	b _{KD}	Sheet pile shoring width	Y	KVL spindle
B _{KD}	Sheet pile width	l _c	Pipe culvert length	b _{cDK}	Piling frame clear width	Z	Support bracket with bolt

BLU piling frame elements

Art. no.	Short description	l [m]	lc [m]	G / DKP [kg]	G / Box [kg]	KD / Box
842 703	BLU piling frame element for CR435 piles	2.41	2.17	190.0	473.0 *	12
842 701	BLU piling frame element for KD IV piles	2.41	2.17	190.0	473.0 *	14

* With spindle 70 × 650

Spindle types

Art. no.	Short description	l [m]	G [kg]
118 060	Spindle 70 × 650	0.523–0.617	12.2
118 070	Spindle 70 × 740	0.613–0.797	13.4
118 090	Spindle 70 × 920	0.799–1.161	15.8
118 020	Spindle 70 × 1280	1.153–1.878	20.5
118 100	Spindle 70 × 1470	1.339–2.254	24.0

Shoring widths for CR435/KD IV piles

Art. no.	Short description	Lift [m]	bcKD [m]	bcDK [m]
118 060	Spindle 70 × 650	0.094	0.695–0.787	0.533–0.627
118 070	Spindle 70 × 740	0.184	0.783–0.967	0.623–0.807
118 090	Spindle 70 × 920	0.362	0.969–1.331	0.809–1.171
118 020	Spindle 70 × 1280	0.725	1.323–2.048	1.163–1.888
118 100	Spindle 70 × 1470	0.915	1.500–2.425	1.349–2.265

Shoring widths for CR435 piles

$$b_{KD} = b_{cKD} + 0.076 \text{ m}$$

$$b_{DK} = b_{cDK} + 0.360 \text{ m}$$

Shoring widths for KD IV piles

$$b_{KD} = b_{cKD} + 0.096 \text{ m}$$

$$b_{DK} = b_{cDK} + 0.380 \text{ m}$$

l	Length	G / Box	Weight / shoring box	b _{cKD}	Sheet pile clear width	b _{KD}	Sheet pile shoring width
lc	Pipe culvert length	KD / Box	Sheet piles / shoring box	b _{cDK}	Piling frame clear width	b _{DK}	Piling frame shoring width
G / DKP	Weight / sheet piling element						

KRINGS Universal DKU piling frame element



General data

Shoring length	2.27 m / 3.81 m
Piling frame element height	1.00 m
Pipe culvert length	1.82 m / 3.35 m
Shoring depth	variable
Box weight	1,335 kg–1,885 kg
Shoring width	variable

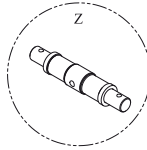
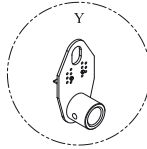
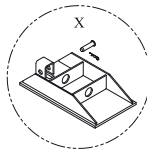
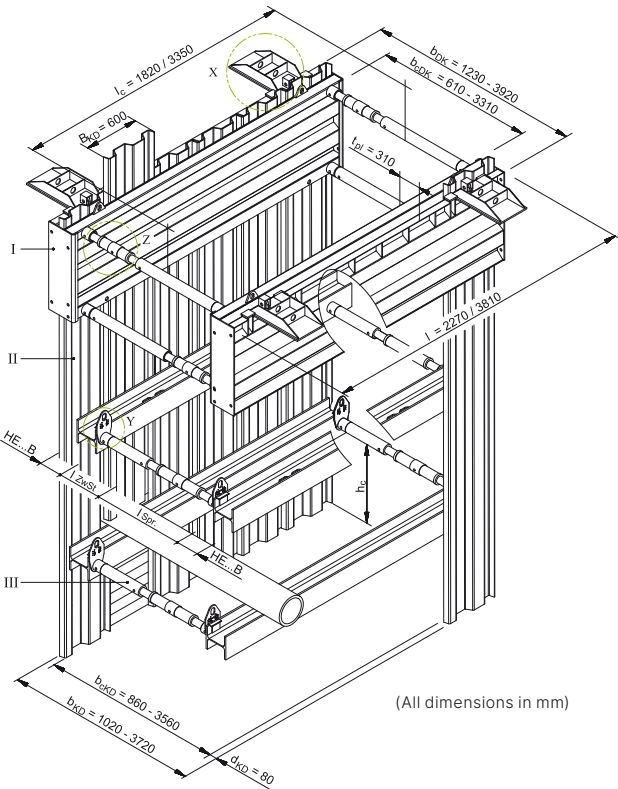

- I Universal DKU piling frame element
- II Sheet pile
- III Waler strut
- B_{KD} Sheet pile width
- d_{KD} Sheet pile thickness
- t_{pl} Panel thickness
- l Length
- l_c Pipe culvert length
- h_c Pipe culvert height
- b_{cKD} Sheet pile clear width
- b_{KD} Sheet pile shoring width
- b_{cDK} Piling frame clear width
- b_{DK} Piling frame shoring width
- X Support bracket
- Y Suspended bearing block
- Z Spindle 98 x ...

Example for additional technical solutions: Piling frame shoring with corner joint

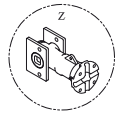
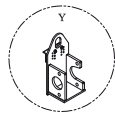
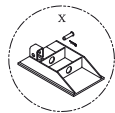
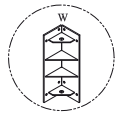
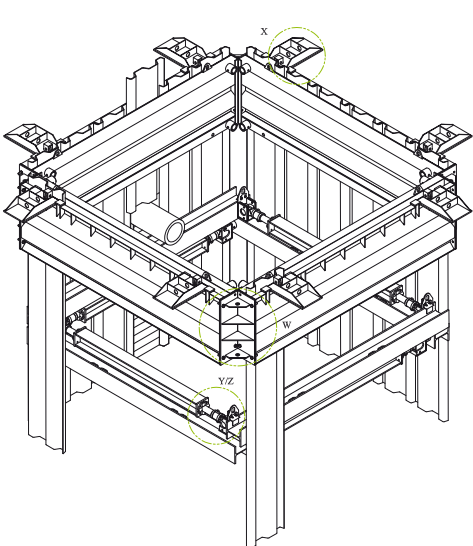

- W Corner joint
- X Support bracket
- Y Suspended bearing block
- Z Strut with bearing panel

Universal DKU piling frame elements (height 1.00 m)

Art. no.	Short description	l [m]	lc [m]	G / DKP [kg]	G / Box [kg]	KD / Box
842 671	Universal DKU piling frame element	2.27	1.82	510.0	1,335.0*	8
842 674	Universal DKU piling frame element	3.81	3.35	785.0	1,885.0*	14

* With spindle 98 × 700

Shoring widths

Extension bar	l [m]	SP SB 98 × 550		SP SB 98 × 700	
		b _{cKD} [m]	b _{cDK} [m]	b _{cKD} [m]	b _{cDK} [m]
	0.00	0.86–1.06	0.61–0.81	1.04–1.38	0.79–1.13
139 430	0.30	1.16–1.36	0.91–1.11	1.34–1.68	1.09–1.43
139 445	0.50	1.36–1.56	1.11–1.31	1.54–1.88	1.29–1.63
139 385	1.00	1.86–2.06	1.61–1.81	2.04–2.38	1.79–2.13
139 400	1.50	2.36–2.56	2.11–2.31	2.54–2.88	2.29–2.63
139 420	2.00	2.86–3.06	2.61–2.81	3.04–3.38	2.79–3.13
139 425	2.50	3.36–3.56	3.11–3.31	3.54–3.88	3.29–3.63
		b _{KD} = b _{cKD} + 0.16 m	b _{DK} = b _{cDK} + 0.62 m	b _{KD} = b _{cKD} + 0.16 m	b _{DK} = b _{cDK} + 0.62 m

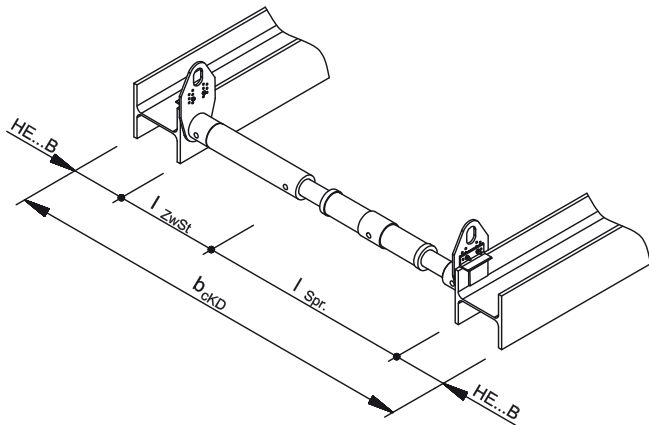
Waler struts
KRINGS Waler strut

$l_{Spr.}$ (SP SB 98 × 550) = 620 mm – 820 mm
 $l_{Spr.}$ (SP SB 98 × 700) = 796 mm – 1,136 mm
 $l_{zwSt.} = b_{cKD} - 2 \times HE...B - l_{Spr.}$

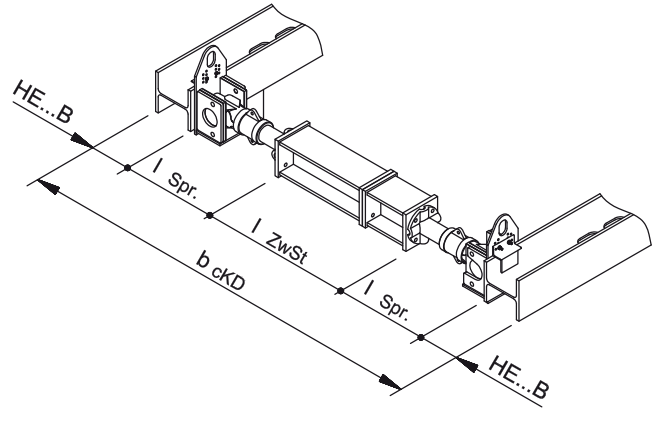
E+S Waler strut

$l_{Spr.} = 420 \text{ mm} - 640 \text{ mm}$
 $l_{zwSt.} = b_{cKD} - 2 \times HE...B - 2 \times l_{Spr.}$

Different trench widths possible by combination of different extension bar lengths.
For available extension bars, refer to accessories.

l	Length	l _{zwSt.}	Extension bar length	b _{cDK}	Piling frame clear width	A	Surface
lc	Pipe culvert length	b _{cKD}	Sheet pile clear width	b _{DK}	Piling frame shoring width	G / DKP	Weight / sheet piling element
l _{Spr.}	Strut length	b _{KD}	Sheet pile shoring width	KD / Box	Number of sheet piles / shoring box	G / Box	Weight / shoring box

E+S DKE 3.63 and 4.03 piling frame element

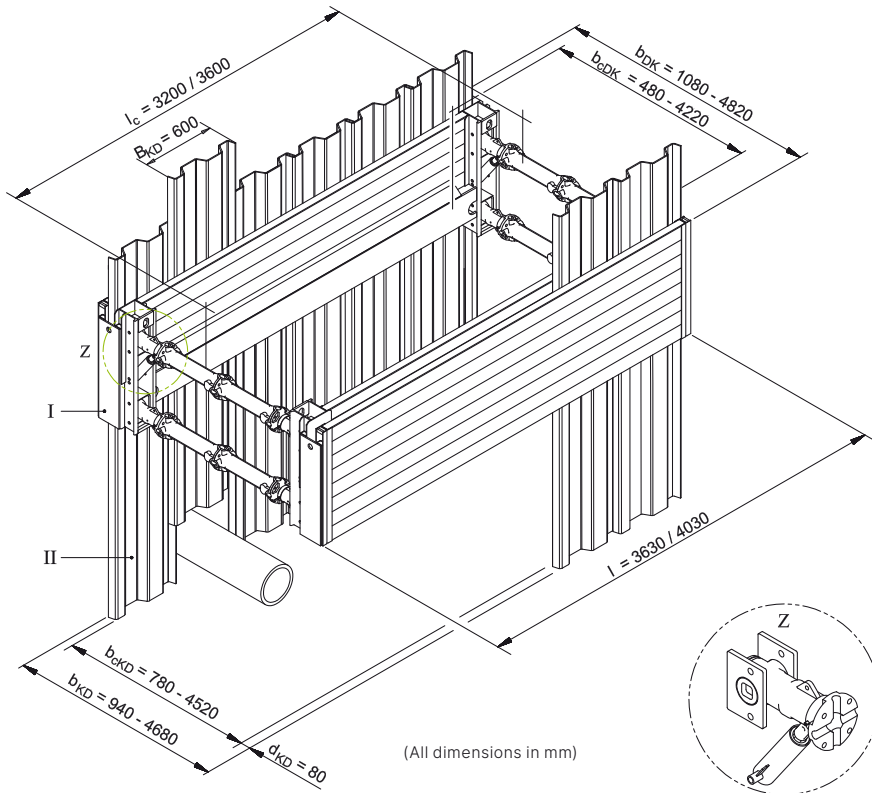

General data

Shoring length	3.63 m / 4.03 m
Piling frame element height	1.00 m
Pipe culvert length	3.20 / 3.60 m
Shoring depth	variable
Box weight	1,884 kg / 1,980 kg
Shoring width	variable

- I DKE piling frame element
- II Sheet pile
- B_{KD} Sheet pile width
- d_{KD} Sheet pile thickness
- l Length
- l_c Pipe culvert length
- b_{cKD} Sheet pile clear width
- b_{KD} Sheet pile shoring width
- b_{cDK} Piling frame clear width
- b_{DK} Piling frame shoring width
- Z Strut with bearing panel and stabilizer

DKE 3.63 m and 4.03 m piling frame elements

Art. no.	Short description	l [m]	l _c [m]	G / DKP [kg]	G / Box [kg]	KD / Box
842 540	Piling frame element	3.63	3.20	942.0	1,884.0	12
842 580	Piling frame element	4.03	3.60	990.0	1,980.0	14

Extension bars

Art. no.	Short description	l [m]	G [kg]
850 091	Cast pipe extension bar	0.250	11.2
850 100	Cast pipe extension bar	0.550	18.7
850 112	HEB 180 extension bar	0.275	28.0
850 110	HEB 180 extension bar	0.550	43.0
850 124	HEB 180 extension bar	1.100	70.0
850 132	HEB 180 extension bar	1.650	100.0
850 135	HEB 180 extension bar	2.200	130.0

Shoring widths (for extension bars l = 0.550 m)

Extension bars	b _{cKD} [m]	b _{KD} [m]	b _{cDK} [m]	b _{DK} [m]	l	Length
0	0.78–1.22	0.94–1.38	0.48–0.92	1.08–1.52	l _c	Pipe culvert length
1	1.33–1.77	1.49–1.93	1.03–1.47	1.67–2.11	b _{cKD}	Sheet pile clear width
2	1.88–2.32	2.04–2.48	1.58–2.02	2.22–2.66	b _{KD}	Sheet pile shoring width
3	2.43–2.87	2.59–3.03	2.13–2.57	2.77–3.21	b _{cDK}	Piling frame clear width
4	2.98–3.42	3.14–3.58	2.68–3.12	3.32–3.76	b _{DK}	Piling frame shoring width
5	3.53–3.97	3.69–4.13	3.23–3.67	3.87–4.31	G	Weight
6	4.08–4.52	4.24–4.68	3.78–4.22	4.42–4.82	G / DKP	Weight / sheet piling element
					G / Box	Weight / shoring box
					KD / Box	Number of sheet piles / box

KRINGS DKU 5.80 piling frame element

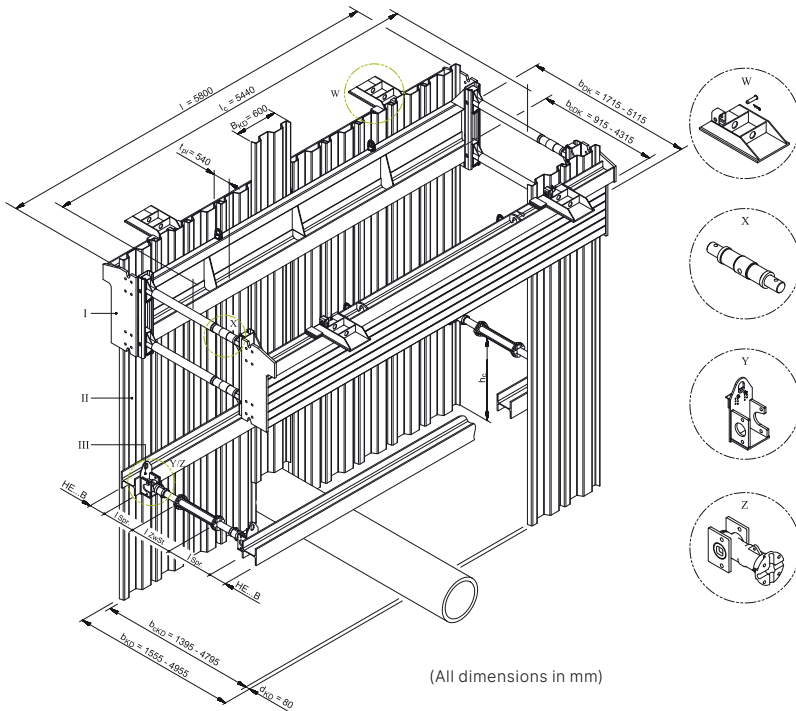

General data

Shoring length	5.80 m
Piling frame element height	1.10 m
Pipe culvert length	5.44 m
Shoring depth	variable
Box weight	4,226 kg
Shoring width	variable

I	DKU piling frame element	b _{CKD}	Sheet pile clear width
II	Sheet pile	b _{KD}	Sheet pile shoring width
III	Waler strut	b _{CDK}	Piling frame clear width
B _{KD}	Sheet pile width	b _{DK}	Piling frame shoring width
d _{KD}	Sheet pile thickness	W	Support bracket
t _{pl}	Panel thickness	X	Spindle 98 × ...
l	Length	Y	Suspended bearing block
l _c	Pipe culvert length	Z	Strut with bearing panel
h _c	Pipe culvert height		

Example for additional technical solutions: Piling frame shoring with corner joint

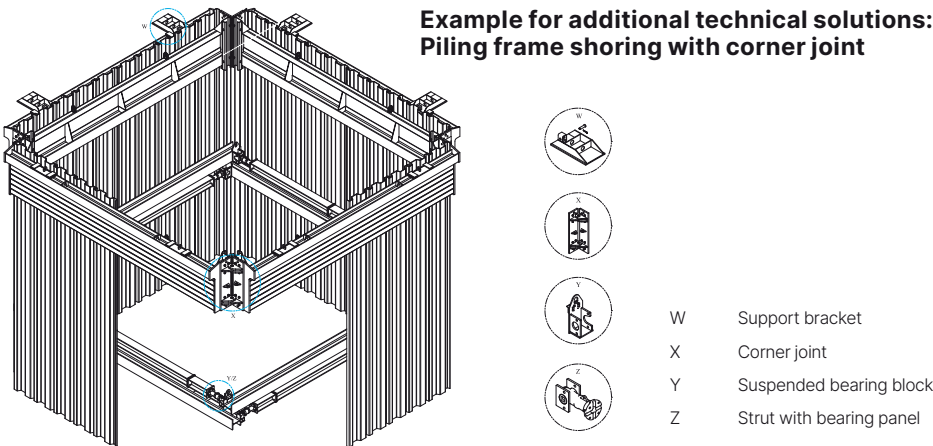

DKU 5.80 m piling frame elements

Art. no.	Short description	l [m]	l _c [m]	G / DKP [kg]	G / Box [kg]	KD / Box
842 699	Piling frame element	5.80	5.44	1,880.0	4,226.0*	20

* With spindle 98 × 817

DKU 5.80 m shoring widths with spindle 98 × 817

Extension bars	l [m]	b _{CKD} [m]	b _{KD} [m]	b _{CDK} [m]	b _{DK} [m]		
0	0.00	1.395–1.795	1.555–1.955	0.915–1.315	1.715–2.115	l	Length
1	0.50	1.895–2.295	2.055–2.455	1.415–1.815	2.215–2.615	l _c	Pipe culvert length
2	1.00	2.395–2.795	2.555–2.955	1.915–2.315	2.715–3.115	b _{CKD}	Sheet pile clear width
3	1.50	2.895–3.295	3.055–3.455	2.415–2.815	3.215–3.615	b _{CDK}	Piling frame clear width
4	2.00	3.395–3.795	3.555–3.955	2.915–3.315	3.715–4.115	b _{DK}	Piling frame shoring width
5	2.50	3.895–4.295	4.055–4.455	3.415–3.815	4.215–4.615	b _{KD}	Sheet pile shoring width
6	3.00	4.395–4.795	4.555–4.955	3.915–4.315	4.715–5.115	G / DKP	Weight / sheet piling element
						G / Box	Weight / shoring box
						KD / Box	Sheet piles / box

Aluminum lightweight shoring



General data

Shoring length	0.91 m–3.00 m
Base unit height	0.50 m
Installation depth	max. 4.00 m
Shoring width	max. 2.18 m
Weight	variable

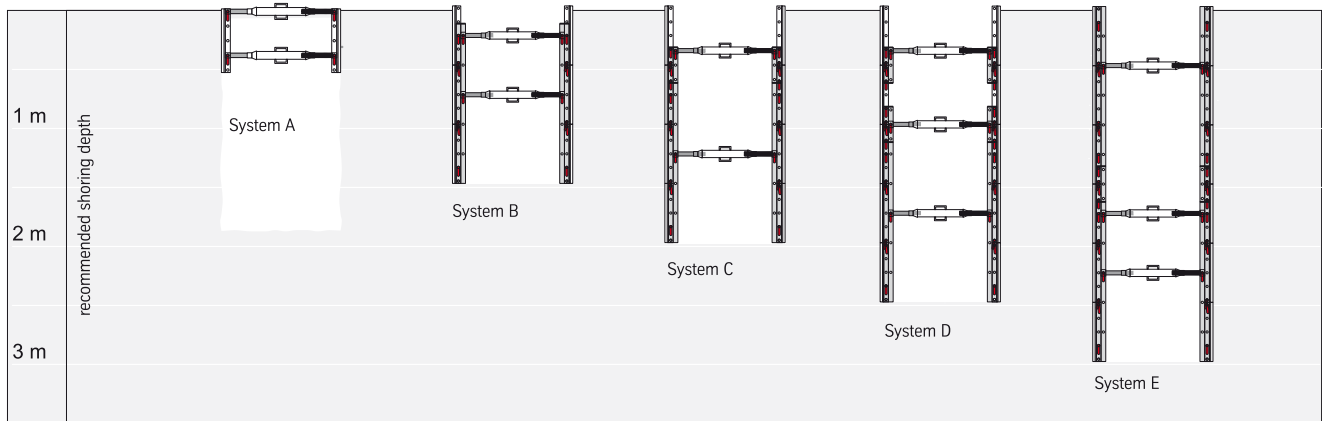

	System layout A	System layout B	System layout C	System layout D	System layout E
Installation area					
Shoring depth [m]	0.50	1.50	2.00	2.50	3.00
Shoring widths [m]	0.60–2.18	0.68–2.26	0.68–2.26	0.68–2.26	0.68–2.26
Max. pipe opening height [m]	-	0.75	0.75	0.75	0.75
Maximum weight [kg] with Gi-A/129-218 trench struts					
Aluminum panels 1.55 m	93	213	268	346	411
Aluminum panels 2.00 m	103	242	307	394	469
Aluminum panels 2.55 m	119	292	374	478	569
Aluminum panels 3.00 m	130	325	417	532	635
Number of components					
Gi-A trench struts	4	4	4	6	6
Aluminum panels	2	6	8	10	12
Aluminum couplings 0.28 m	-	-	4	8	4
Aluminum couplings 1.35 m	-	4	4	4	8
Standard positioning bolt Ø 13 mm	8	32	48	68	76

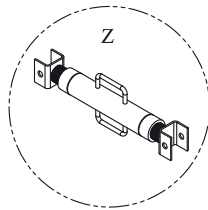
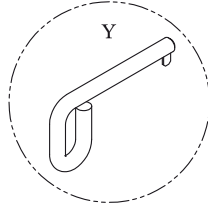
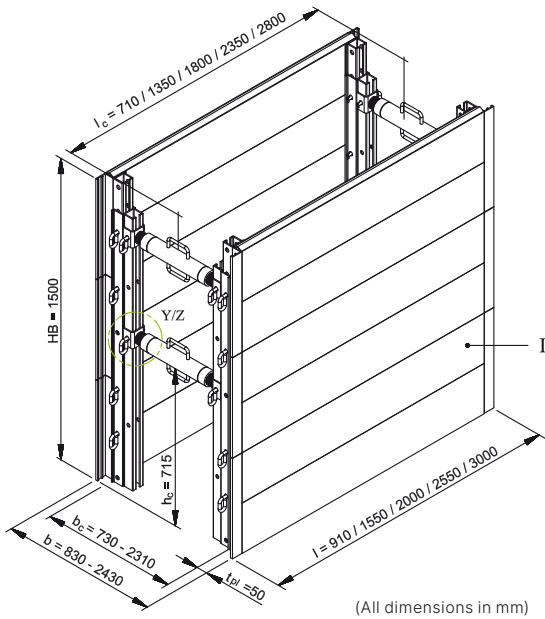

- I Aluminum shoring panel
- HB Unit height
- l Length
- lc Pipe culvert length
- b Shoring/trench width
- bc Clear width
- hc Pipe culvert height
- tpl Panel strength
- Y Positioning bolt
- Z Shoring strut

Base units (aluminum shoring panel)

Art. no.	Short description	l [m]	h [m]	hc [m]	G / VP [kg]
804 100	Aluminum panel	0.91	0.50	0.22	13.0
804 150	Aluminum panel	1.55	0.50	0.22	21.0
804 200	Aluminum panel	2.00	0.50	0.22	28.0
804 210	Aluminum panel	2.55	0.50	0.22	37.0
804 250	Aluminum panel	3.00	0.50	0.22	42.0

Aluminum couplings

Art. no.	Short description	l [m]	G [kg]
804 280	Aluminum coupling	0.28	2.0
804 300	Aluminum coupling	1.35	6.5
804 310	Aluminum coupling	1.85	9.0

Extension bars

Art. no.	Short description	l [m]	G [kg]
804 400	GI-A60-81 cm trench struts incl. 2 bolts	0.60-0.81	5.5
804 500	GI-A80-121 cm trench struts incl. 2 bolts	0.80-1.21	7.3
804 550	GI-A 129-218 cm trench struts incl. 2 bolts	1.29-2.18	11.5

Shoring widths (aluminum shoring panel)

Trench strut	without coupling		with coupling		
	Lift [m]	bc [m]	b [m]	bc [m]	b [m]
Gi-A / 60-81	0.21	0.50-0.71	0.60-0.81	0.58-0.79	0.68-0.89
Gi-A / 80-121	0.41	0.70-1.11	0.80-1.21	0.78-1.19	0.88-1.29
Gi-A / 129-218	0.89	1.19-2.08	1.29-2.18	1.27-2.16	1.37-2.26

- l Length
- h Panel height
- hc Pipe culvert height
- b Trench width
- bc Clear width
- G Weight
- G/VP Weight/shoring panel

KRINGS Flex shoring



General data

Shoring/panel length	2.00 m–3.00 m
Unit height	0.50 m–2.00 m
Pipe culvert height	0.22 m / 0.60 m
Pile thickness	5 cm / 6 cm / 7 cm
Shoring depth	max. 2.00 m
Shoring width	variable

Flex shoring combination examples with heights 1.00 m, 1.50 m and 2.00 m

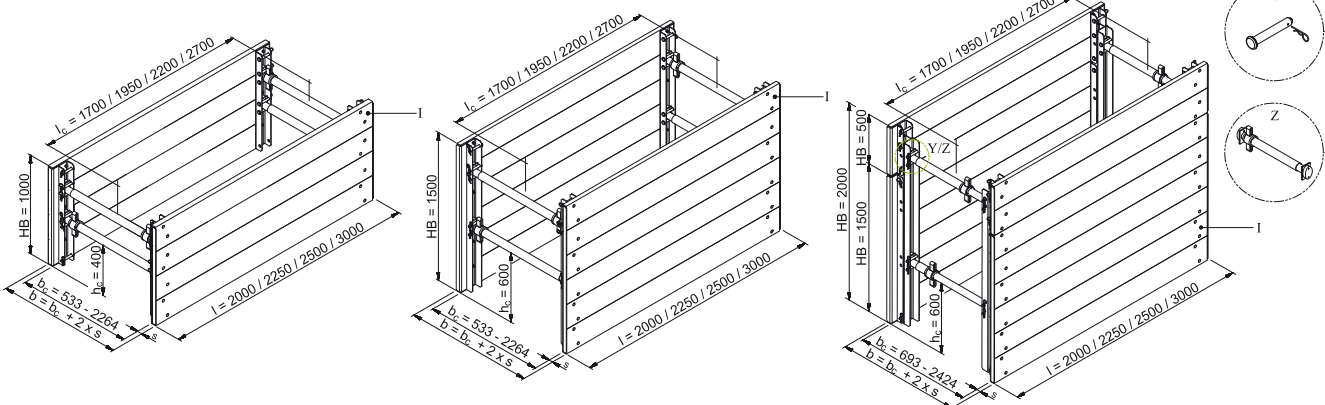

Wooden panels with a height of 0.25 m and lengths between 2.00 m and 3.00 m as well as M 10 round-head screws and M 10 nuts must be provided on site.

- I Flex shoring unit
- l Length
- lc Pipe culvert length
- b Shoring/trench width
- bc Clear width
- Hb Unit height
- hc Pipe culvert height
- s Pile thickness
- Y Positioning bolt
- Z KVL spindle

Cross beams

Art. no.	Short description	h [m]	hc [m]	G [kg]
888 401	Basic/attachment cross beam	0.50	0.22	7.6
888 410	Basic cross beam	1.00	0.41	18.6
888 400	Basic cross beam	1.50	0.60	25.7

Shoring widths

Art. no.	Short description	Lift [m]	bc [m]	b [m]	G [kg]
118 060	Spindle 70 × 650	0.094	0.533–0.627	0.547–0.641	12.2
118 070	Spindle 70 × 740	0.184	0.623–0.807	0.637–0.821	13.4
118 090	Spindle 70 × 920	0.362	0.809–1.171	0.823–1.185	15.8
118 020	Spindle 70 × 1280	0.725	1.163–1.888	1.177–1.902	20.5
118 100	Spindle 70 × 1470	0.915	1.349–2.264	1.363–2.278	24.0

Dimensional minimum system resistance [kN/m²] with wood panels

for pile thickness s [cm]

Shoring length	Support width	4	5	6	7
2.00 m	1.76 m	10.2	15.9	22.9	31.2
2.25 m	2.01 m	7.8	12.2	17.6	23.9
2.50 m	2.26 m	6.2	9.6	13.9	18.9
3.00 m	2.76 m	4.1	6.5	9.3	12.7

(EC5, NH S10, performance class 2)

- h Panel height
- hc Pipe culvert height
- b Trench width
- bc Clear width
- G Weight

Accessories and spare parts

KVL spindle 70 × 650 / 740 / 920 / 1280 / 1470

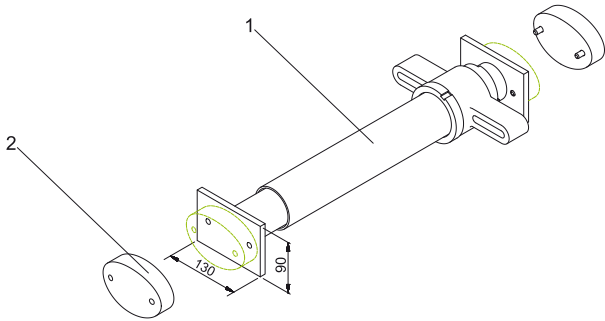

- | | | | |
|---|-------------------------|---|---------------|
| 1 | Spindle | 3 | Adapter |
| 2 | Rubber buffer (ellipse) | 4 | Extension bar |

KS spindle with KVL adapter 98 × 550 / 700

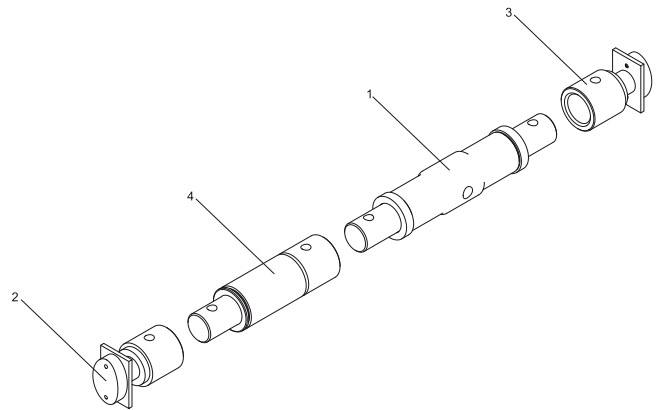

Spindle 98 × 550 / 700

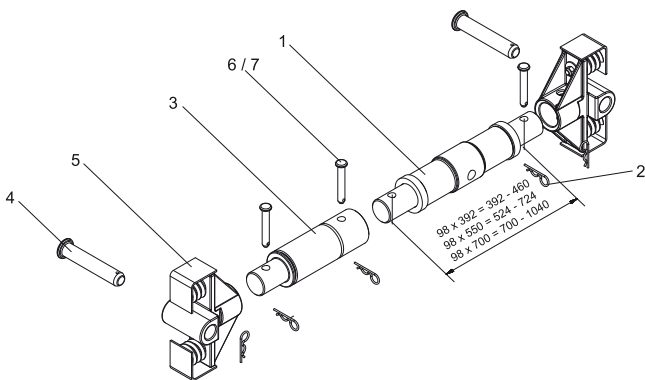

- | | | | |
|---|-------------------------|---|---------------|
| 1 | Spindle | 4 | Bolt 212 × 43 |
| 2 | Spring connector | 5 | Spring socket |
| 3 | Extension pipe, plug-in | 6 | Bolt 125 × 20 |

Spindle 98 × 817

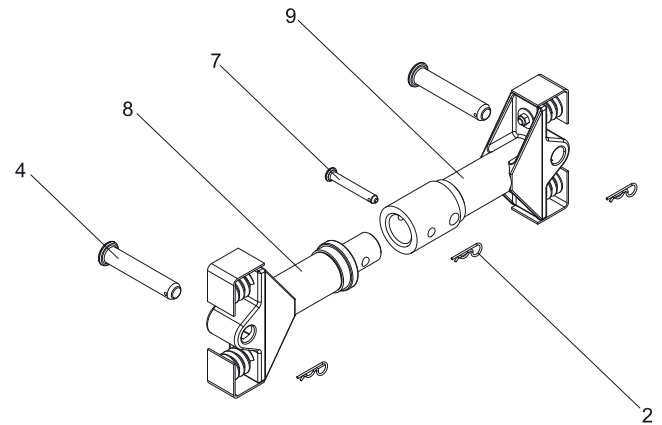

- | | |
|---|---------------------|
| 7 | Bolt 140 × 20 |
| 8 | Spindle half, left |
| 9 | Spindle half, right |

E+S Strut fully right/left with stabilizer

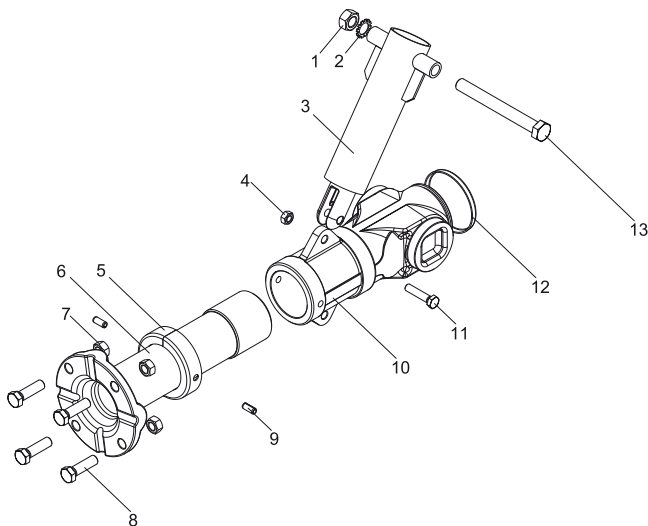

- | | |
|----|-----------------------------------|
| 1 | M 20 nut |
| 2 | A 20 toothed washer |
| 3 | Stabilizer |
| 4 | M 12 nut |
| 5 | Protective cover half for spindle |
| 6 | Spindle right/left |
| 7 | M 16 nut |
| 8 | Hex. screw M 16 × 55 |
| 9 | Clamping sleeve 10 × 24 mm |
| 10 | Cast nut right/left |
| 11 | Hex. screw M 12 × 55 |
| 12 | Protective cover |
| 13 | Hex. screw M 20 × 180 |

Accessories and spare parts

Art. no.	Short description	l [m]	d [m]	G [kg]
821 100	Chain 13/ 5,000 mm	5.00		25.7
850 614	Positioning bolt 200 × 40 mm (linear box strut cart)			1.9
138 030	Bolt 125 × 20 (spindle 98 × 550 / 700, KVL, BLU)	0.125	0.02	0.4
138 040	Bolt 140 × 20 (spindle 98 × 817)	0.14	0.02	0.4
138 070	Bolts 212 × 43 (spring socket, posts KS 60, KS 60 Eck, KS 100, KS 100 Eck)	0.212	0.043	2.5
843 343	Bolts Ø 40 × 150 mm incl. spring connector (adapter DKU 5.80 m)			3.5
HE 0050 F	Spring connector 6.0 mm (E+S Boxes)		0.006	0.03
159 161	Pipe clip 60 × 6 (E+S Linear box)			0.10
138 200	Spring connector FS 92 × 5 (KRINGS Boxes)	0.092	0.005	0.1
IB 0215 F	Screw M 12 × 55–8.8 galv. (connection stabilizer-cast nut, E+S)			0.06
IB 0310 F	Screw M 16 × 55–8.8 galv. (extension bars, E+S)			0.11
IB 0420 F	Screw M 20 × 180–4.6 galv. (stabilizer, E+S)			0.56
IB 0360 F	Screw M 20 × 45–8.8 galv. (bearing panel, E+S)			0.17
IB 0515 F	Screw M 24 × 100–8.8 galv. (adapter DKU 5.80 m)			0.42
IB 0545 F	Screw M 30 × 80–10.9 galv. (extension bars, E+S Linear box)			0.6
IA 0095 F	Nut M 55–8.0 (connection stabilizer-cast nut, E+S)			0.01
IA 0120 F	Nut M 16–8.0 galv. (extension bars, E+S)			0.03
IA 0130 F	Nut M 20–8.0 galv. (stabilizer, bearing panel, E+S)			0.03
IA 0140 F	Nut M 24–8.0 galv. (adapter DKU 5.80 m)			0.11
IA 0185 F	Nut M 30–10.0 galv. (extension bars, E+S Linear box)			0.30
HD 0110 F	Cast nut lubrication nipple		0.01	0.01
138 170	FP 80 spring socket			13.0
850 510	Connector (lightweight shoring)			3.1
862 214	Connector (Linearbox, top unit with struts)			6.1
850 500	Connector (Medium shoring, Magnum shoring)			6.7
139 100	Connector (KS 60, KS 60 Eck, KS 100, KS 100 Eck)			5.5
850 610	Connector bolts (lightweight shoring)	0.10	0.03	0.50
850 600	Connector studs (Medium, Magnum shoring)	0.20	0.04	1.8
118 060	Spindle 70 × 650			12.2
118 070	Spindle 70 × 740			13.4
118 090	Spindle 70 × 920			15.8
118 020	Spindle 70 × 1280			20.5
118 100	Spindle 70 × 1470			24.0
138 280	Spindle 98 × 550			22.0
138 290	Spindle 98 × 700			34.0
138 300	Spindle 98 × 817			76.9
108 950	Spindle half, left 98 × 817			38.0
108 960	Spindle half, right 98 × 817			39.0
119 011	KVL adapter for spindles 98 × 550 / 98 × 700			7.6
301 000	Struts, left, hollow spindle			19.5
301 010	Struts, left, full spindle			27.1
300 000	Struts, right, hollow spindle			19.5
300 010	Struts, right, full spindle			27.1
300 100	Stabilizer	0.14		4.5
861 076	Pressure beam (Medium, Magnum, KS 100/Eck, Manhole, Linearbox, Dragbox)	1.60		176.0
861 074	Pressure beam (Medium, Magnum, KS 100/Eck, Manhole, Linearbox, Dragbox)	2.35		236.0
861 070	Pressure beam (Medium, Magnum, KS 100/Eck, Manhole, Linearbox, Dragbox)	2.80		271.0

Art. no.	Short description	l [m]	d [m]	G [kg]
861 075	Pressure beam (Magnum 5.08 m)	4.60		425.0
861 090	Pressure beam (Magnum 6.84 m)	2.20		483.0
861 077	Pressure beam (lightweight shoring, KVL, KS 60, KS 60 Eck)	1.80		80.0
861 078	Pressure beam (lightweight shoring, KVL, KS 60, KS 60 Eck)	2.30		95.0
861 079	Pressure beam (lightweight shoring, KVL, KS 60, KS 60 Eck)	2.80		110.0
861 080	Pressure beam (lightweight shoring, KVL, KS 60, KS 60 Eck)	3.30		125.0
851 010	Pressure panel (lightweight shoring)			7.0
851 005	Pressure panel (Medium, Magnum, Manhole, Linearbox)			19.0
842 099	Guide frame for Universal DKU, KD VI piling frame element	2.27		105.0
842 100	Guide frame for Universal DKU, KD VI piling frame element	3.81		175.0
843 358	DKU 5.80 m guide frame			125.0
842 753	Adapter for Universal DKU corner rail shoring, H=1.00 m KD IV			94.0
843 345	Corner shoring adapter, DKU 5.80 m, compl.			230.0
336 960	Support brackets for Universal DKU piling frame element			40.0
859 981	Suspended bearing block, E+S			25.6
859 982	Suspended bearing block, variable, KRINGS			12.0
850 699	Rotary bar for spindle, E+S/KRINGS	0.70	0.02	2.5
302 125	Bearing panel (lightweight shoring, Medium, Magnum, Manhole, Dragbox)			4.2
888 407	Aluminum/Flex shoring coupling	0.83		14.0
888 405	Aluminum/Flex shoring coupling	1.33		21.4
888 406	Aluminum/Flex shoring coupling	1.83		30.0
850 091	Cast pipe extension bar	0.25		11.2
850 100	Cast pipe extension bar	0.55		18.7
850 112	HEB 180 extension bar	0.275		28.0
850 110	HEB 180 extension bar	0.55		43.0
850 124	HEB 180 extension bar	1.10		70.0
850 132	HEB 180 extension bar	1.65		100.0
850 135	HEB 180 extension bar	2.20		130.0
850 105	HEB 220 extension bar	0.275		40.0
850 115	HEB 220 extension bar	0.55		58.0
850 121	HEB 220 extension bar	1.10		98.0
850 130	HEB 220 extension bar	1.65		140.0
850 141	HEB 220 extension bar	2.20		180.0
831 030	IPE 400 extension bar, Linearbox	0.275		57.0
831 040	IPE 400 extension bar, Linearbox	0.55		75.0
831 050	IPE 400 extension bar, Linearbox	1.10		115.0
831 060	IPE 400 extension bar, Linearbox	1.65		155.0
831 070	IPE 400 extension bar, Linearbox	2.20		195.0
139 430	Extension bar 108 × 300 mm	0.30		13.8
139 445	Extension bar 108 × 500 mm	0.50		17.7
139 385	Extension bar 108 × 1,000 mm	1.00		28.0
139 400	Extension bar 108 × 1,500 mm	1.50		37.4
139 420	Extension bar 108 × 2,000 mm	2.00		47.3
139 425	Extension bar 108 × 2,500 mm	2.50		60.0
139 510	Extension bar 121 × 500 mm (spindle 98 × 817)	0.50		25.1
139 470	Extension bar 121 × 1,000 mm (spindle 98 × 817)	1.00		36.3

Slide-rail systems, E+S, linear shoring

Recommended shoring depth: max. 4.00 m

Single slide rail linear shoring
Rec. shoring depth: 4.00 m
Page 42

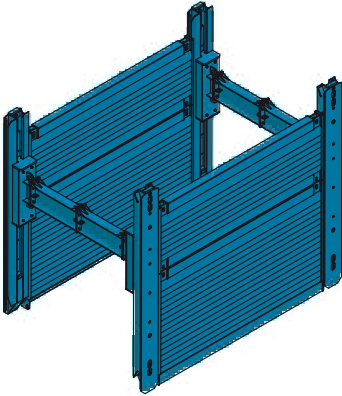

Single slide rail inner-city linear shoring
Rec. shoring depth: 4.00 m
Page 45

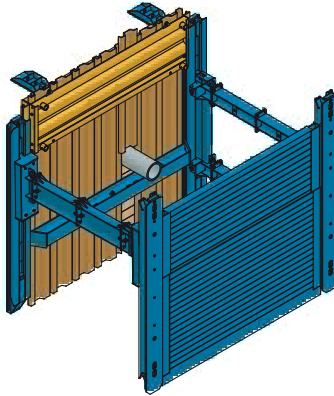

Single slide rail corner shoring
Rec. shoring depth: 4.00 m
Page 48

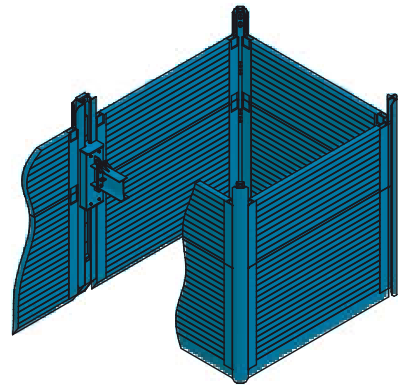

Single slide rail linear shoring – X-rail
Rec. shoring depth: 4.00 m
Page 51

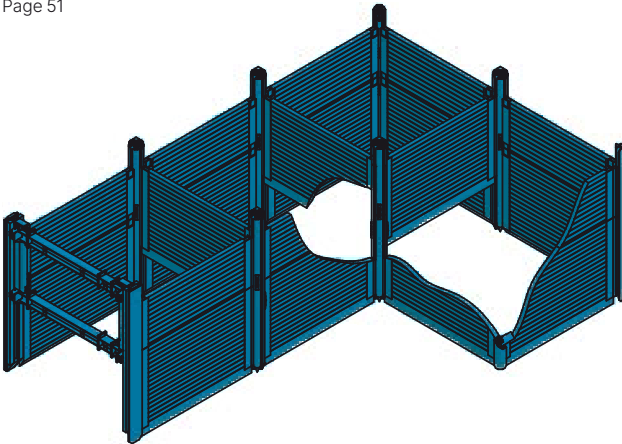

Recommended shoring depth: 5.00 m–9.00 m

Double slide rail linear shoring
Rec. shoring depth: 5.00 m–9.00 m
Page 53

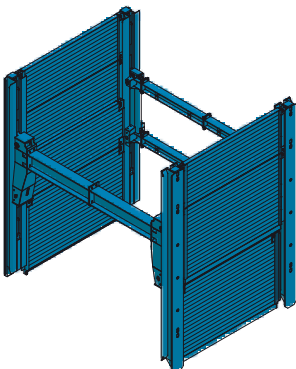

Double slide rail inner-city linear shoring
Rec. shoring depth: 5.00 m–9.00 m
Page 57

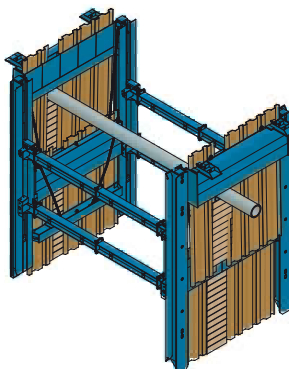

Double slide rail corner shoring
Rec. installation depth 5.00–6.00 m
Page 60

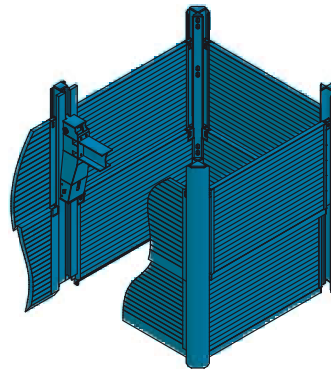

Recommended shoring depth: max. 12.00 m

Deep linear shoring

Rec. shoring depth: max. 12.00 m
Page 63

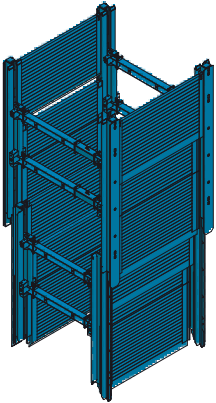

More shoring options

Head end shoring with sheet piles

Rec. installation depth: variable
Page 66

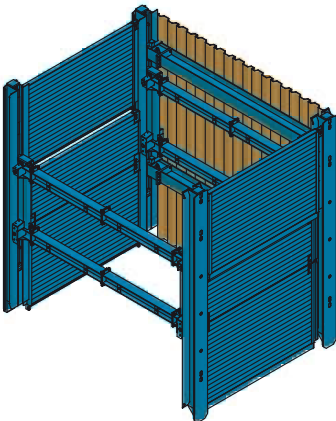

Head end shoring with slide-rail panels

Rec. installation depth: variable
Page 67

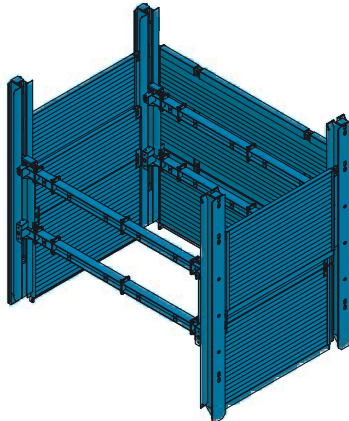

Head end shoring with strut cart and sheet piles

Rec. installation depth: variable;
Page 68

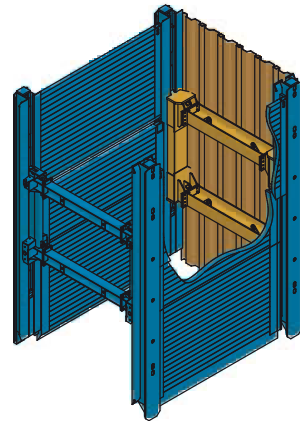

Outer waler attachment

Page 69

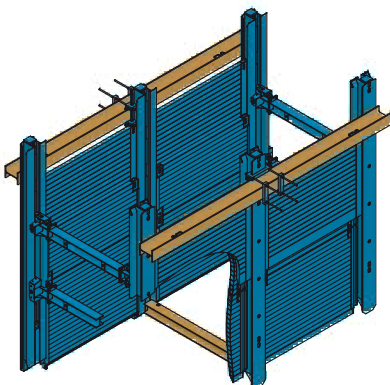

E+S Single slide rail linear shoring



General data

Module length	2.13 m–6.38 m
Slide-rail length	4.13 m
Panel height	1.32 m / 2.32 m
Pipe culvert height	variable
Shoring width	variable

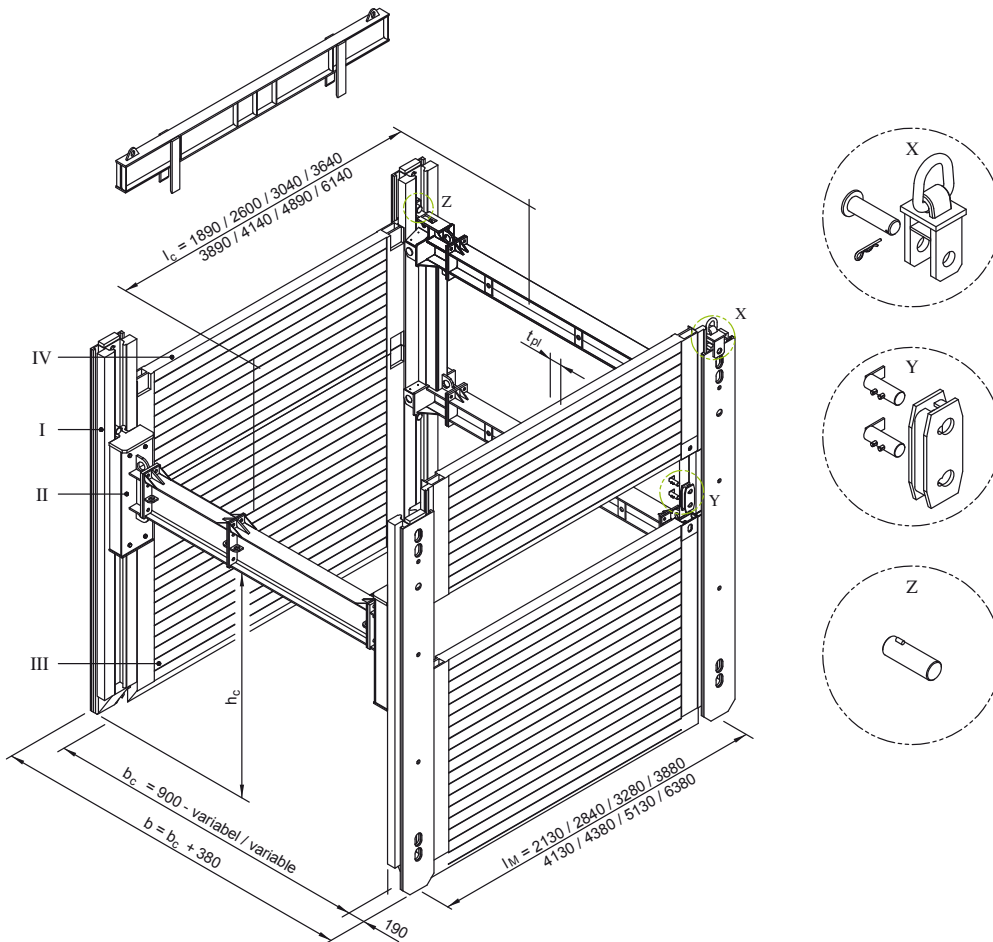

(All dimensions in mm. The data on pipe opening length l_c refer to the rectangular strut cart.)

I	Linear shoring support	l_M	Module length	h_c	Pipe culvert height	Z	Positioning bolt
II	Linear shoring strut cart	l_c	Pipe culvert length	t_{pl}	Panel thickness	X	Drag adapter with bolts
III	Base panel	b	Shoring/trench width	Y	Connector with bolts		
IV	Top panel	b_c	Clear width				

Linear shoring support

Art. no.	Short description	l [m]	G [kg]
820 935	Linear shoring support	4.13	710.0

Linear shoring strut carts

Art. no.	Short description	l [m]	G [kg]
832 200	Rectangular strut cart	2.00	420.0
832 205	U-strut cart	2.00	618.0
832 197	U-strut cart 1.20 m	1.20	340.0

Base panels -inside- (height 2.32 m)

Art. no.	l [m]	l _M [m]	t _{pl} [m]	l _c [m]	G / VP [kg]	A [m ²]	eh [kN/m ²]
821 120	1.89	2.13	0.11	1.89	510.0	4.38	176.0
821 160	2.60	2.84	0.11	2.60	650.0	6.03	90.0
821 250	3.04	3.28	0.11	3.04	730.0	7.05	65.5
821 610	3.64	3.88	0.11	3.64	845.0	8.44	45.2
821 850	3.89	4.13	0.11	3.89	970.0	9.02	39.4
821 855	4.14	4.38	0.15	4.14	1,300.0	9.58	81.0
821 860	4.89	5.13	0.15	4.89	1,500.0	11.34	58.1
821 861	6.13	6.38	0.15	6.13	1,880.0	14.22	36.6

Top panels -inside- (height 1.32 m)

Art. no.	l [m]	l _M [m]	t _{pl} [m]	l _c [m]	G / VP [kg]	A [m ²]	eh [kN/m ²]
822 060	1.89	2.13	0.11	1.89	355.0	2.49	176.0
821 180	2.60	2.84	0.11	2.60	440.0	3.43	90.0
822 120	3.04	3.28	0.11	3.04	500.0	4.01	65.5
822 620	3.64	3.88	0.11	3.64	620.0	4.80	45.2
822 760	3.89	4.13	0.11	3.89	649.0	5.13	39.4
822 783	4.14	4.38	0.15	4.14	870.0	5.45	81.0
822 800	4.89	5.13	0.15	4.89	1,100.0	6.45	58.1
822 801	6.13	6.38	0.15	6.13	1,370.0	8.09	36.6

Top panels -inside- (height 2.30 m)

Art. no.	l [m]	l _M [m]	t _{pl} [m]	l _c [m]	G / VP [kg]	A [m ²]	eh [kN/m ²]
822 065	1.89	2.13	0.11	1.89	530.0	4.35	176.0
822 155	2.60	2.84	0.11	2.60	660.0	5.98	90.0
822 180	3.04	3.28	0.11	3.04	740.0	6.99	65.5
822 680	3.64	3.88	0.11	3.64	850.0	8.37	45.2
822 780	3.89	4.13	0.11	3.89	980.0	8.95	39.4
822 785	4.14	4.38	0.15	4.14	1,435.0	9.50	81.0

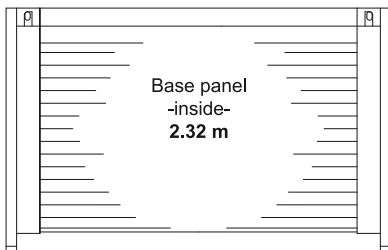
Possible height combinations

Trench depth approx. 2.32 m

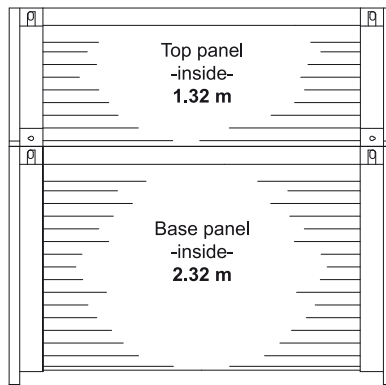

Trench depth approx. 3.60 m

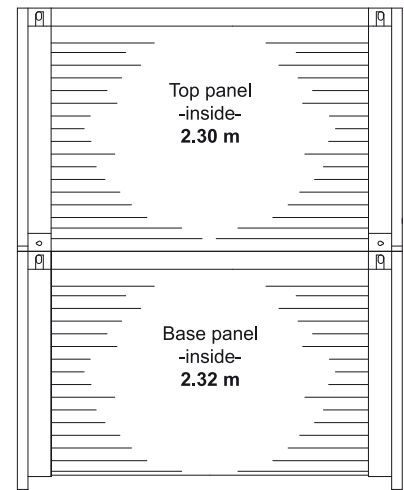

Trench depth approx. 4.60 m

Extension bars for rectangular strut cart

Art. no.	Short description	l [m]	G [kg]
830 005	HEB 220 extension bar	0.140	42.0
830 010	HEB 220 extension bar	0.275	50.0
830 011	HEB 220 extension bar	0.350	55.0
830 012	HEB 220 extension bar	0.375	62.0
830 015	HEB 220 extension bar	0.412	65.0
830 020	HEB 220 extension bar	0.550	70.0
830 030	HEB 220 extension bar	1.100	110.0
830 075	HEB 220 extension bar	1.650	145.0
830 125	HEB 220 extension bar	2.200	192.0
830 300	HEB 220 extension bar	3.300	278.0
830 305	HEB 220 extension bar	4.400	358.0

Extension bars for U-strut cart

Art. no.	Short description	l [m]	G [kg]
831 503	HEA 450 extension bar	0.140	77.0
831 500	HEA 450 extension bar	0.275	107.0
831 507	HEA 450 extension bar	0.375	115.0
831 510	HEA 450 extension bar	0.550	140.0
831 520	HEA 450 extension bar	1.100	220.0
831 530	HEA 450 extension bar	1.650	300.0
831 540	HEA 450 extension bar	2.200	375.0

Extension bars for U-strut cart (1.20 m)

Art. no.	Short description	l [m]	G [kg]
831 030	IPE 400 extension bar	0.275	57.0
831 040	IPE 400 extension bar	0.550	75.0
831 050	IPE 400 extension bar	1.100	115.0
831 060	IPE 400 extension bar	1.650	155.0
831 070	IPE 400 extension bar	2.200	195.0

Accessories/spare parts

Art. no.	Short description	l [m]	d [m]	G [kg]
850 720	Linear shoring positioning bolts	0.15	0.050	2.50
832 230	Bolts, pressure panel, rectangular strut cart	0.15	0.035	1.40
861 076	Pressure beam	1.60		176.00
861 074	Pressure beam	2.35		236.00
861 070	Pressure beam	2.80		271.00
861 071	Pressure beam	3.40		318.00
861 075	Pressure beam	4.60		425.00
861 085	Pressure beam	5.80		525.00
834 015	Strut cart pressure panel			12.40
HE 0050 F	Spring connector 6,0 mm		0.006	0.03
IA 0150 F	Nut M 24–10,9 galv. (rectangular strut cart)			0.10
IA 0185 F	Nut M 30–10,9 galv. (U-strut cart 1,20 m)			0.30
IA 0210 F	Nut M 36–10,9 galv. (U-strut cart)			0.40
862 200	Connector			5.50
862 100	Connector bolts	0.11	0.035	1.00
IB 0470 F	Screw M 24 × 80–10,9 galv. (rectangular strut cart)			0.40
IB 0545 F	Screw M 30 × 80–10,9 galv. (U-strut cart 1,20 m)			0.64
IB 0614 F	Screw M 36 × 80–10,9 galv. (U-strut cart)			1.00
834 057	Drag adapter with bolts			33.00

Shoring widths for rectangular and U-strut cart

Extension bar length [m]	b _c [m]	b [m]
without extension bar	0.90	1.28
0.140	1.04	1.42
0.275	1.18	1.56
0.350	1.25	1.63
0.375	1.28	1.66
0.412	1.31	1.69
0.550	1.45	1.83
1.100	2.00	2.38
1.650	2.55	2.93
2.200	3.10	3.48
3.300	4.20	4.58
4.400	5.30	5.68

Other trench widths possible by combination of different extension bar lengths.

Shoring widths for U-strut cart (1.20 m)

Extension bar length [m]	b _c [m]	b [m]
without extension bar	0.70	1.08
0.275	0.98	1.36
0.550	1.25	1.63
1.100	1.80	2.18
1.650	2.35	2.73
2.200	2.90	3.28

l	Length	A	Surface
l _M	Module length	G	Weight
l _c	Pipe culvert length	G / VP	Weight / shoring panel
t _{pl}	Panel thickness	eh	Admissible soil pressure
b	Shoring width	b _c	Clear width
d	Diameter		

E+S Single slide rail inner-city linear shoring



General data

Module length	2.84 m–4.38 m
Slide-rail length	4.13 m
Piling frame element height	1.00 m
Pipe culvert height	variable
Shoring width	variable
Sheet pile length (KD VI/8)	variable

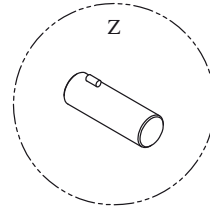
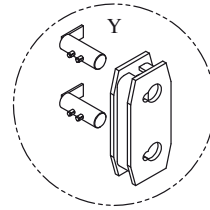
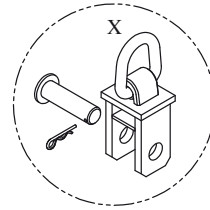
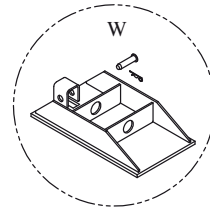
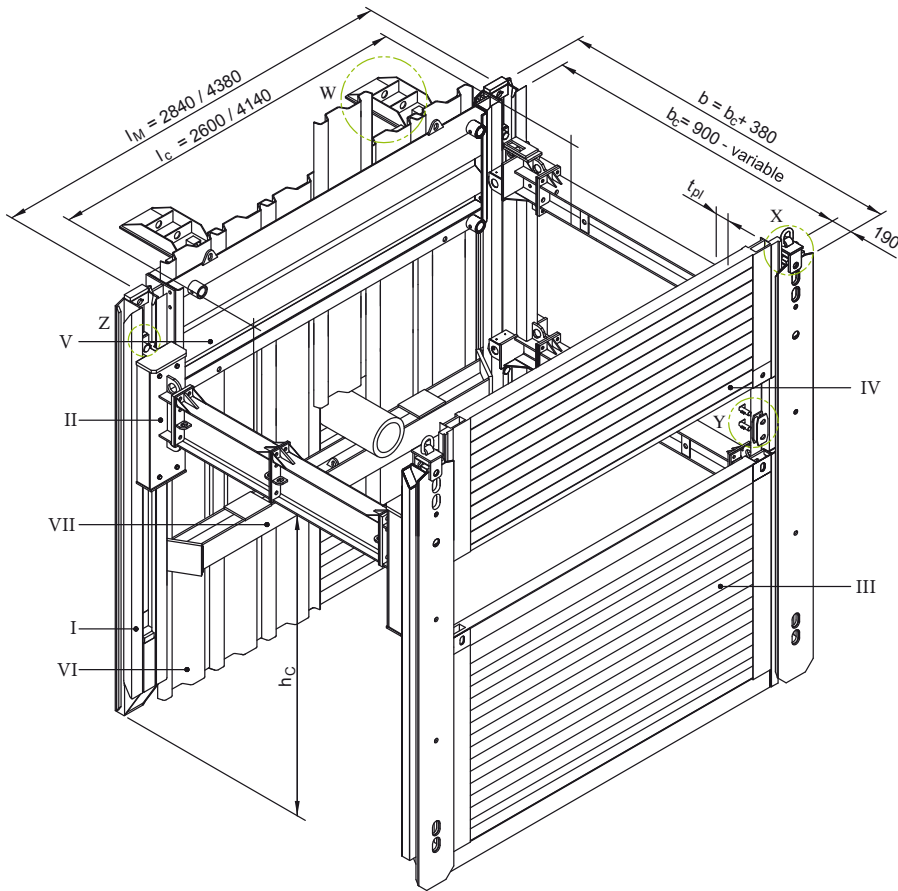

(All dimensions in mm. The data on pipe opening length l_c refer to the rectangular strut cart.)

I	Linear shoring support	VI	KD VI/8 sheet piles	b_c	Clear width	Y	Connector with bolts
II	Linear shoring strut cart	VII	Waler soldier	h_c	Pipe culvert height	Z	Positioning bolt
III	Base panel	l_m	Module length	t_{pi}	Panel thickness		
IV	Top panel	l_c	Pipe culvert length	W	Support bracket		
V	Universal DKU piling frame element	b	Shoring/trench width	X	Drag adapter with bolts		

Linear shoring support

Art. no.	Short description	l [m]	G [kg]
820 935	Linear shoring support	4.13	710.0

Linear shoring strut carts

Art. no.	Short description	l [m]	G [kg]
832 200	Rectangular strut cart	2.00	420.0
832 205	U-strut cart	2.00	618.0
832 197	U-strut cart 1.20 m	1.20	340.0

Piling frame elements

Art. no.	Short description	l [m]	l _M [m]	t _{pl} [m]	l _c [m]	G/DKP [kg]
842 671	Universal DKU, KD VI piling frame element	2.27	2.84	0.31	1.75	510.0
842 674	Universal DKU, KD VI piling frame element	3.81	4.38	0.31	3.29	785.0

Base panels -inside- (height 2.32 m)

Art. no.	l [m]	l _M [m]	t _{pl} [m]	l _c [m]	G / VP [kg]	A [m ²]	eh [kN/m ²]
821 160	2.60	2.84	0.11	2.60	650.0	6.03	90.0
821 855	4.14	4.38	0.15	4.14	1,300.0	9.58	81.0

Top panels -inside- (height 1.32 m)

Art. no.	l [m]	l _M [m]	t _{pl} [m]	l _c [m]	G / VP [kg]	A [m ²]	eh [kN/m ²]
821 180	2.60	2.84	0.11	2.60	440.0	3.43	90.0
822 783	4.14	4.38	0.15	4.14	870.0	5.45	81.0

Top panels -inside- (height 2.30 m)

Art. no.	l [m]	l _M [m]	t _{pl} [m]	l _c [m]	G / VP [kg]	A [m ²]	eh [kN/m ²]
822 155	2.60	2.84	0.11	2.60	660.0	5.98	90.0
822 785	4.14	4.38	0.15	4.14	1,409.0	9.50	81.0

Walers, inner-city linear shoring

Art. no.	Short description	l [m]	l _M [m]	G/VP [kg]
842 704	Waler for Universal DKU piling frame element, module length 2.84 m	2.60	2.84	300.0
842 711	Waler for Universal DKU piling frame element, module length 4.38 m	4.14	4.38	445.0

Extension bars for rectangular strut cart

Art. no.	Short description	l [m]	G [kg]
830 005	HEB 220 extension bar	0.140	42.0
830 010	HEB 220 extension bar	0.275	50.0
830 011	HEB 220 extension bar	0.350	55.0
830 012	HEB 220 extension bar	0.375	62.0
830 015	HEB 220 extension bar	0.412	65.0
830 020	HEB 220 extension bar	0.550	70.0
830 030	HEB 220 extension bar	1.100	110.0
830 075	HEB 220 extension bar	1.650	145.0
830 125	HEB 220 extension bar	2.200	192.0
830 300	HEB 220 extension bar	3.300	278.0
830 305	HEB 220 extension bar	4.400	358.0

Extension bars for U-strut cart

Art. no.	Short description	l [m]	G [kg]
831 503	HEA 450 extension bar	0.140	77.0
831 500	HEA 450 extension bar	0.275	107.0
831 507	HEA 450 extension bar	0.375	115.0
831 510	HEA 450 extension bar	0.550	140.0
831 520	HEA 450 extension bar	1.100	220.0
831 530	HEA 450 extension bar	1.650	300.0
831 540	HEA 450 extension bar	2.200	375.0

Extension bars for U-strut cart (1.20 m)

Art. no.	Short description	l [m]	G [kg]
831 030	IPE 400 extension bar	0.275	57.0
831 040	IPE 400 extension bar	0.550	75.0
831 050	IPE 400 extension bar	1.100	115.0
831 060	IPE 400 extension bar	1.650	155.0
831 070	IPE 400 extension bar	2.200	195.0

Shoring widths for rectangular and U-strut cart

Extension bar length [m]	b _c [m]	b [m]
without extension bar	0.90	1.28
0.140	1.04	1.42
0.275	1.18	1.56
0.350	1.25	1.63
0.375	1.28	1.66
0.412	1.31	1.69
0.550	1.45	1.83
1.100	2.00	2.38
1.650	2.55	2.93
2.200	3.10	3.48
3.300	4.20	4.58

Other trench widths possible by combination of different extension bar lengths.

Shoring widths for U-strut cart (1.20 m)

Extension bar length [m]	b _c [m]	b [m]
without extension bar	0.70	1.08
0.275	0.98	1.36
0.550	1.25	1.63
1.100	1.80	2.18
1.650	2.35	2.73
2.200	2.90	3.28

Accessories/spare parts

Art. no.	Short description	l [m]	d [m]	G [kg]
821 100	Chain 13/ 5,000 mm	5.00		25.7
850 720	Linear shoring positioning bolts	0.15	0.05	2.5
842 751	Adapter for Universal DKU piling frame element, H=1.00 m KD VI			75.5
336 960	Support brackets for Universal DKU piling frame element incl. bolts and spring connector			40.0
832 230	Bolts, pressure panel, rectangular strut cart	0.15	0.035	1.4
861 076	Pressure beam	1.60		176.0
861 074	Pressure beam	2.35		236.0
861 070	Pressure beam	2.80		271.0
861 071	Pressure beam	3.40		318.0
861 075	Pressure beam	4.60		425.0
861 085	Pressure beam	5.80		525.0
834 015	Strut cart pressure panel			12.4
HE 0050 F	Spring connector 6.0 mm		0.006	0.03
IA 0150 F	Nut M 24–10.9 galv. (rectangular strut cart)			0.10
IA 0185 F	Nut M 30–10.9 galv. (U-strut cart 1.20 m)			0.30
IA 0210 F	Nut M 36–10.9 galv. (U-strut cart)			0.40
862 200	Connector			5.5
862 100	Connector bolts	0.11	0.035	1.0
IB 0470 F	Screw M 24 × 80–10.9 galv. (rectangular strut cart)			0.40
IB 0545 F	Screw M 30 × 80–10.9 galv. (U-strut cart 1.20 m)			0.64
IB 0614 F	Screw M 36 × 80–10.9 galv. (U-strut cart)			1.0
834 057	Drag adapter with bolts			33.0

l	Length	t _{pl}	Panel thickness	A	Surface	eh	Admissible soil pressure
l _M	Module length	b	Shoring width	G	Weight	b _c	Clear width
l _c	Pipe culvert length	d	Diameter	G / VP	Weight / shoring panel	G / DKP	Weight / sheet piling element

E+S Single slide rail corner shoring



General data

Module length	2.13 m–6.38 m
Slide-rail length	2.30 m / 4.13 m
Panel height	1.32 m / 2.32 m
Shoring width	1.75 m–6.00 m

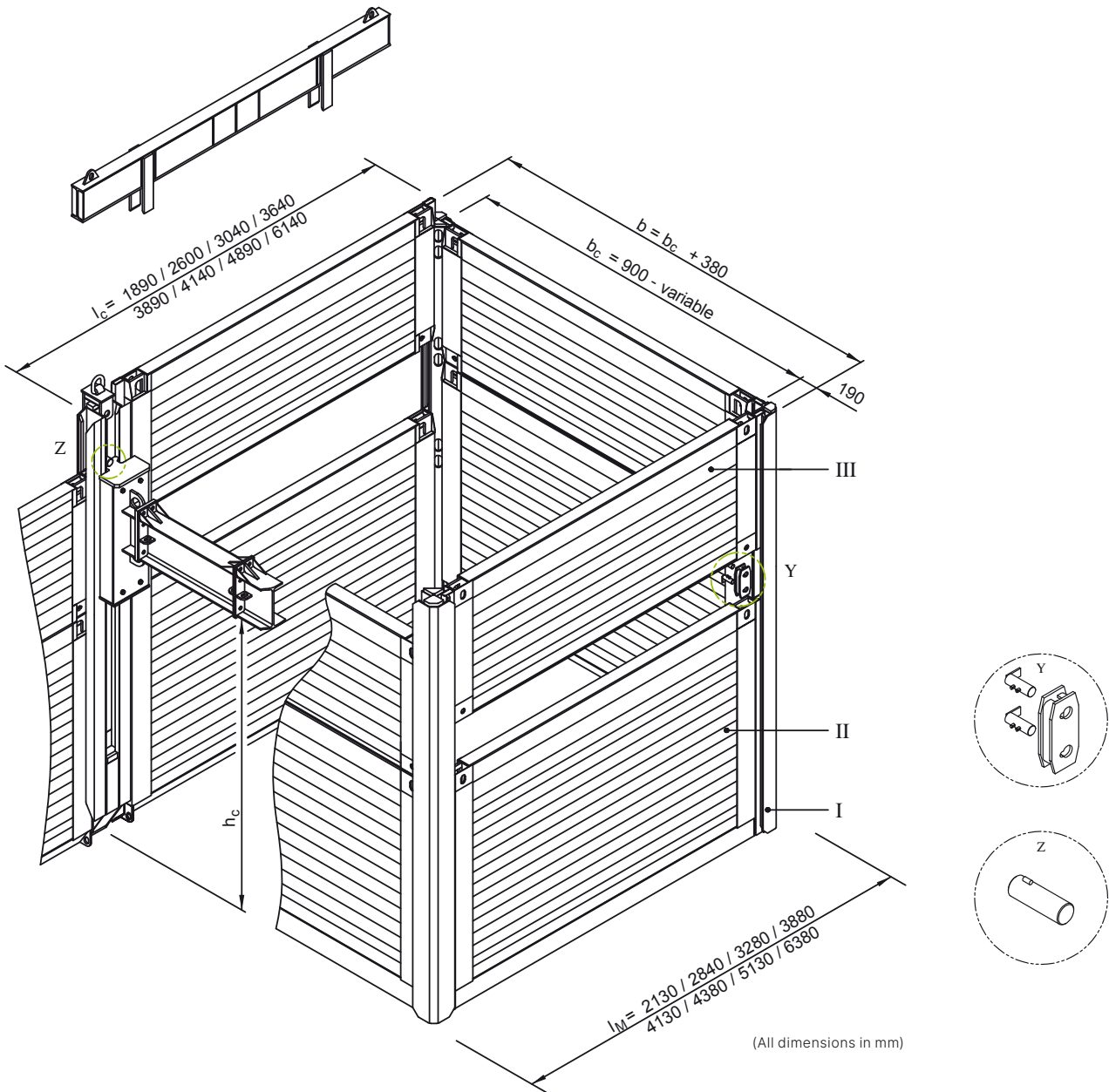

I	Corner shoring support	l_M	Module length	b_c	Clear width	Y	Connector with bolts
II	Base panel	l_c	Pipe culvert length	h_c	Pipe culvert height	Z	Positioning bolt
III	Top panel	b	Shoring/trench width	l_{zwst}	Extension bar length	l_a	Shoring width

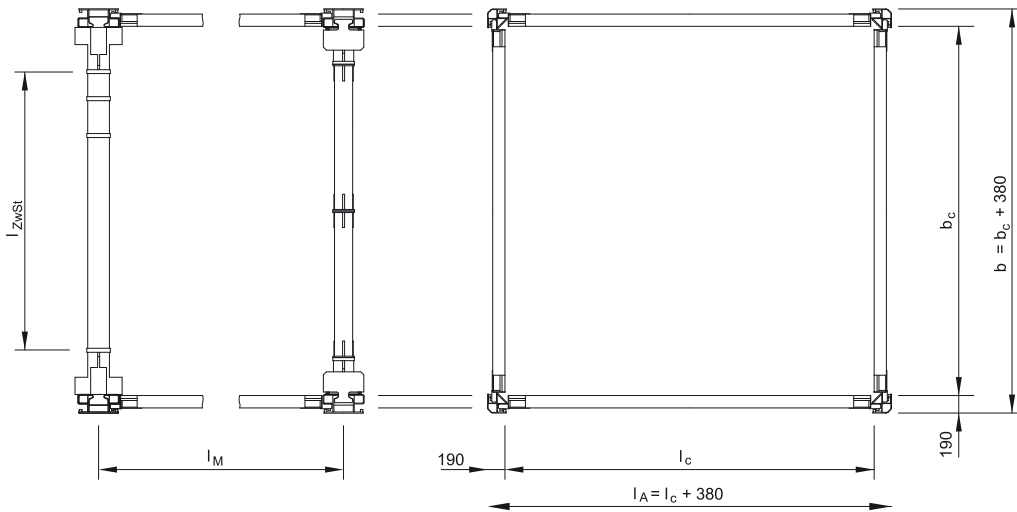

Linear shoring supports

Art. no.	Short description	l [m]	G [kg]
835 129	Corner shoring support	2.30	170.0
835 130	Corner shoring support	4.13	325.0

Base panels -inside- (height 2.32 m)

Art. no.	l [m]	l _M [m]	t _{pl} [m]	l _c [m]	G / VP [kg]	A [m ²]	eh [kN/m ²]
821 120	1.89	2.13	0.11	1.89	510.0	4.38	176.0
821 160	2.60	2.84	0.11	2.60	650.0	6.03	90.0
821 250	3.04	3.28	0.11	3.04	730.0	7.05	65.5
821 610	3.64	3.88	0.11	3.64	845.0	8.44	45.2
821 850	3.89	4.13	0.11	3.89	970.0	9.02	39.4
821 855	4.14	4.38	0.15	4.14	1,300.0	9.58	81.0
821 860	4.89	5.13	0.15	4.89	1,500.0	11.34	58.1
821 861	6.13	6.38	0.15	6.13	1,880.0	14.22	36.6

Top panels -inside- (height 1.32 m)

Art. no.	l [m]	l _M [m]	t _{pl} [m]	l _c [m]	G / VP [kg]	A [m ²]	eh [kN/m ²]
822 060	1.89	2.13	0.11	1.89	355.0	2.49	176.0
821 180	2.60	2.84	0.11	2.60	440.0	3.43	90.0
822 120	3.04	3.28	0.11	3.04	500.0	4.01	65.5
822 620	3.64	3.88	0.11	3.64	620.0	4.80	45.2
822 760	3.89	4.13	0.11	3.89	649.0	5.13	39.4
822 783	4.14	4.38	0.15	4.14	870.0	5.45	81.0
822 800	4.89	5.13	0.15	4.89	1,100.0	6.45	58.1
822 801	6.13	6.38	0.15	6.13	1,370.0	8.09	36.6

Top panels -inside- (height 2.30 m)

Art. no.	l [m]	l _M [m]	t _{pl} [m]	l _c [m]	G / VP [kg]	A [m ²]	eh [kN/m ²]
822 065	1.89	2.13	0.11	1.89	530.0	4.35	176.0
822 155	2.60	2.84	0.11	2.60	660.0	5.98	90.0
822 180	3.04	3.28	0.11	3.04	740.0	6.99	65.5
822 680	3.64	3.88	0.11	3.64	850.0	8.37	45.2
822 780	3.89	4.13	0.11	3.89	980.0	8.95	39.4
822 785	4.14	4.38	0.15	4.14	1,435.0	9.50	81.0

Installation options

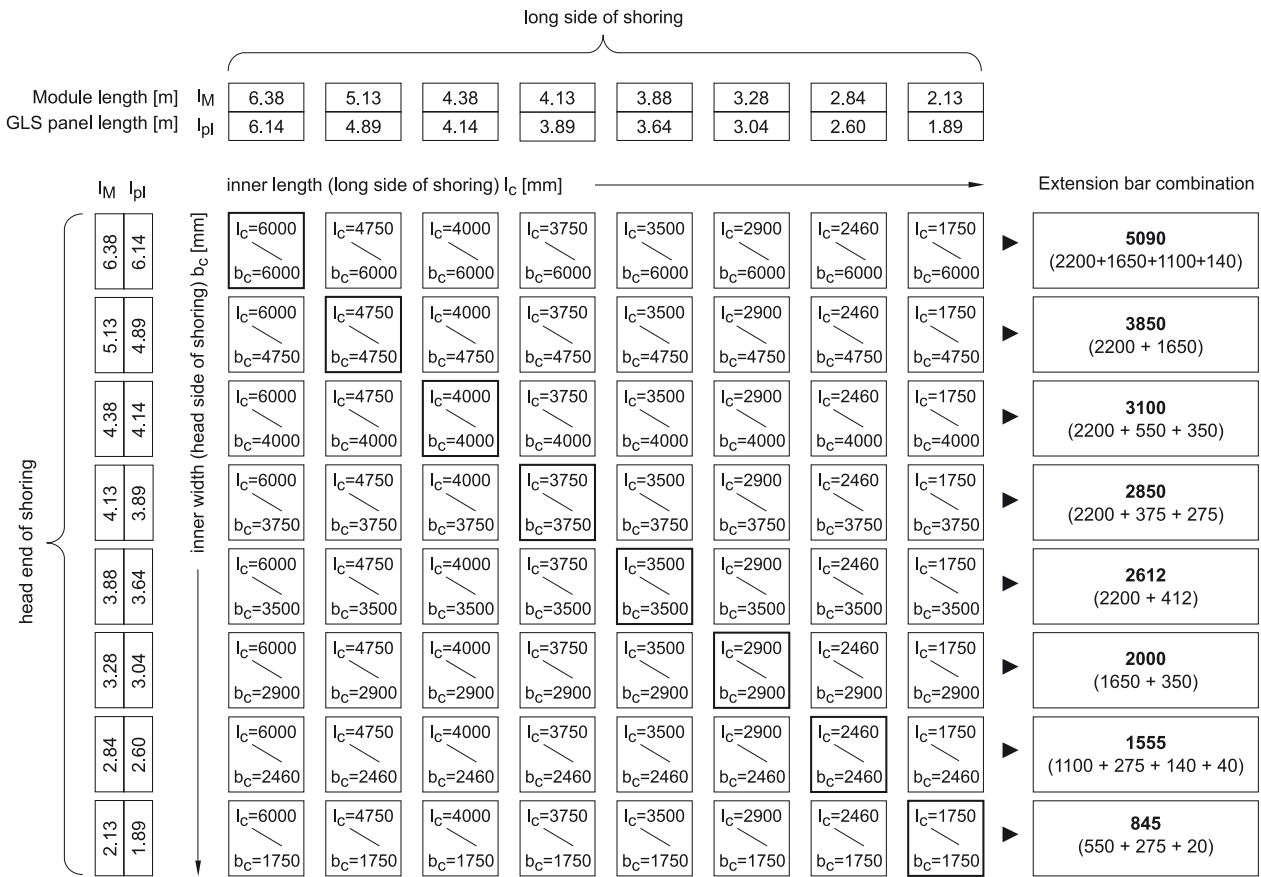

Example:
 Head end shoring module length $l_M = 3.28$ m
 Required extension bar combination for strut cart in linear shoring field: 2,000 mm

Accessories/spare parts

Art. no.	Short description	l [m]	d [m]	G [kg]
861 076	Pressure beam	1.60		176.00
861 074	Pressure beam	2.35		236.00
861 070	Pressure beam	2.80		271.00
861 071	Pressure beam	3.40		318.00
861 075	Pressure beam	4.60		425.00
861 085	Pressure beam	5.80		525.00
862 200	Connector			5.50
862 100	Connector bolts	0.11	0.035	1.00

l	Length	A	Surface	t_{pl}	Panel thickness	eh	Admissible soil pressure
l_M	Module length	G	Weight	b	Shoring width	b_c	Clear width
l_c	Pipe culvert length	G / VP	Weight / shoring panel	d	Diameter	l_{pl}	Panel length

E+S Single slide rail linear shoring – X-rail



General data

Module length	2.13 m–6.38 m
X-rail length	4.13 m
Panel height	1.32 m / 2.32 m
Shoring width	1.75 m–6.00 m

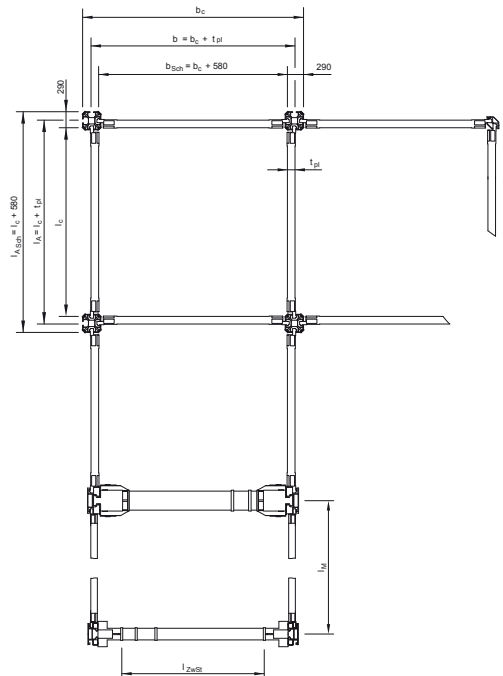
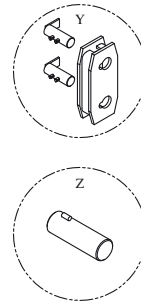
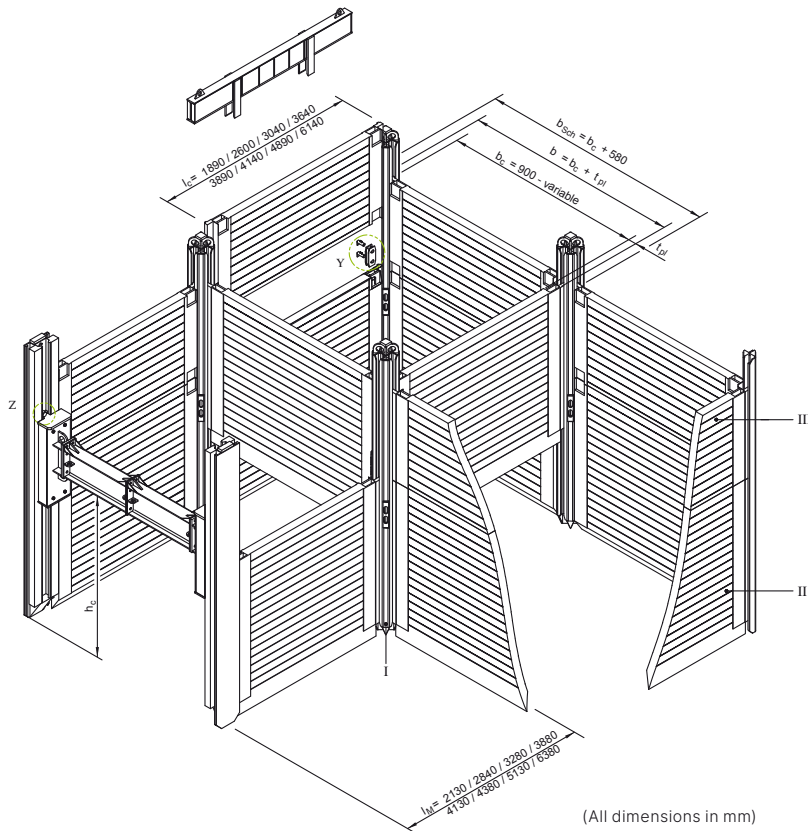

- | | | | | | | | |
|----------------|---------------|----------------|----------------------|-------------------|-----------------------|-----------------|----------------------|
| I | X-rail | l _c | Pipe culvert length | b _{sch} | Rail outer width | t _{pl} | Panel thickness |
| II | Base panel | b | Shoring/trench width | l _A | Shoring/trench length | Y | Connector with bolts |
| III | Top panel | b _c | Clear width | l _{Asch} | Rail outer length | Z | Positioning bolt |
| l _M | Module length | h _c | Pipe culvert height | l _{zwst} | Extension bar length | | |

Linear shoring support

Art. no.	Short description	l [m]	G [kg]
835 160	X-rail	4.13	700.0

Base panels -inside- (height 2.32 m)

Art. no.	l [m]	l _M [m]	t _{pl} [m]	l _c [m]	G / VP [kg]	A [m ²]	eh [kN/m ²]
821 120	1.89	2.13	0.11	1.89	510.0	4.38	176.0
821 160	2.60	2.84	0.11	2.60	650.0	6.03	90.0
821 250	3.04	3.28	0.11	3.04	730.0	7.05	65.5
821 610	3.64	3.88	0.11	3.64	845.0	8.44	45.2
821 850	3.89	4.13	0.11	3.89	970.0	9.02	39.4
821 855	4.14	4.38	0.15	4.14	1,300.0	9.58	81.0
821 860	4.89	5.13	0.15	4.89	1,500.0	11.34	58.1
821 861	6.13	6.38	0.15	6.13	1,880.0	14.22	36.6

Top panels -inside- (height 1.32 m)

Art. no.	l [m]	l _M [m]	t _{pl} [m]	l _c [m]	G / VP [kg]	A [m ²]	eh [kN/m ²]
822 060	1.89	2.13	0.11	1.89	355.0	2.49	176.0
821 180	2.60	2.84	0.11	2.60	440.0	3.43	90.0
822 120	3.04	3.28	0.11	3.04	500.0	4.01	65.5
822 620	3.64	3.88	0.11	3.64	620.0	4.80	45.2
822 760	3.89	4.13	0.11	3.89	649.0	5.13	39.4
822 783	4.14	4.38	0.15	4.14	870.0	5.45	81.0
822 800	4.89	5.13	0.15	4.89	1,100.0	6.45	58.1
822 801	6.13	6.38	0.15	6.13	1,370.0	8.09	36.6

Top panels -inside- (height 2.30 m)

Art. no.	l [m]	l _M [m]	t _{pl} [m]	l _c [m]	G / VP [kg]	A [m ²]	eh [kN/m ²]
822 065	1.89	2.13	0.11	1.89	530.0	4.35	176.0
822 155	2.60	2.84	0.11	2.60	660.0	5.98	90.0
822 180	3.04	3.28	0.11	3.04	740.0	6.99	65.5
822 680	3.64	3.88	0.11	3.64	850.0	8.37	45.2
822 780	3.89	4.13	0.11	3.89	980.0	8.95	39.4
822 785	4.14	4.38	0.15	4.14	1,435.0	9.50	81.0

Accessories/spare parts

Art. no.	Short description	l [m]	d [m]	G [kg]
861 076	Pressure beam	1.60		176.00
861 074	Pressure beam	2.35		236.00
861 070	Pressure beam	2.80		271.00
861 071	Pressure beam	3.40		318.00
861 075	Pressure beam	4.60		425.00
861 085	Pressure beam	5.80		525.00
862 200	Connector			5.50
862 100	Connector bolts	0.11	0.035	1.00

l	Length	A	Surface	G / VP	Weight / shoring panel	d	Diameter
l _M	Module length	G	Weight	t _{pl}	Panel thickness	eh	Admissible soil pressure
l _c	Pipe culvert length						

E+S Double slide rail linear shoring



General data

Module length	2.25 m–6.50 m
Slide-rail length	5.13 m / 6.13 m / 7.13 m / 8.13 m / 9.13 m
Panel height	1.32 m / 2.32 m
Pipe culvert height	variable
Shoring width	variable

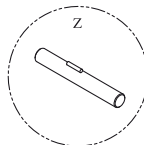
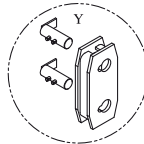
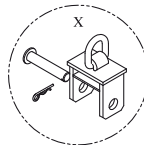
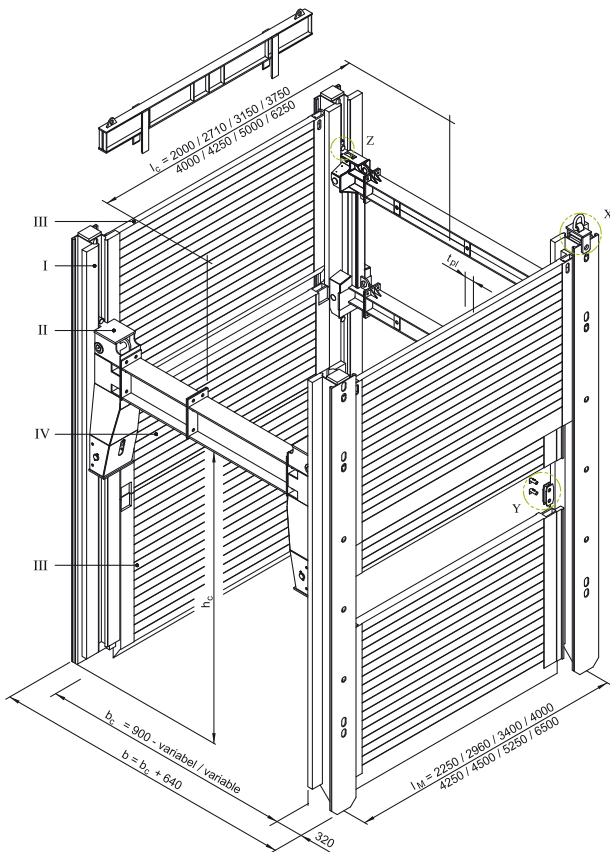

- I Linear shoring support
- II Linear shoring strut cart
- III Base panel
- IV Top panel
- l_M Module length
- l_c Pipe culvert length
- b Shoring/trench width
- b_c Clear width
- h_c Pipe culvert height
- t_{pl} Panel thickness
- X Drag adapter with bolts
- Y Connector with bolts
- Z Positioning bolt

Swiveling-in of shoring panels

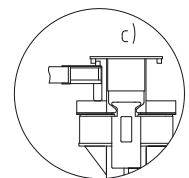
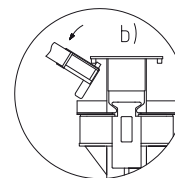
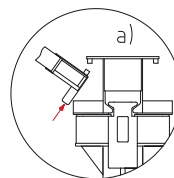

(All dimensions in mm. The data on pipe opening length l_c refer to the rectangular strut cart.)

Linear shoring supports

Art. no.	Short description	l [m]	G [kg]
820 912	Linear shoring support	5.13	1,002.0
820 915	Linear shoring support	6.13	1,192.0
820 920	Linear shoring support	7.13	1,404.0
820 924	Linear shoring support	8.13	1,859.0
820 929	Linear shoring support	9.13	2,325.0

Linear shoring strut carts

Art. no.	Short description	l [m]	G [kg]
832 200	Rectangular strut cart	2.00	420.0
832 215	Rectangular strut cart with self-aligning roller, bottom	2.20	490.0
832 205	U-strut cart	2.00	618.0

Base panels -inside- (height 2.32 m)

Art. no.	l [m]	l _M [m]	t _{pl} [m]	l _c [m]	G / VP [kg]	A [m ²]	eh [kN/m ²]
821 120	1.89	2.25	0.11	2.00	510.0	4.38	176.0
821 160	2.60	2.96	0.11	2.71	650.0	6.03	90.0
821 250	3.04	3.40	0.11	3.15	730.0	7.05	65.5
821 610	3.64	4.00	0.11	3.75	845.0	8.44	45.2
821 850	3.89	4.25	0.11	4.00	970.0	9.02	39.4
821 855	4.14	4.50	0.15	4.25	1,300.0	9.58	81.0
821 860	4.89	5.25	0.15	5.00	1,500.0	11.34	58.1
821 861	6.13	6.50	0.15	6.25	1,880.0	14.22	36.6

Top panels -inside- (height 1.32 m)

Art. no.	l [m]	l _M [m]	t _{pl} [m]	l _c [m]	G / VP [kg]	A [m ²]	eh [kN/m ²]
822 060	1.89	2.25	0.11	2.00	355.0	2.49	176.0
821 180	2.60	2.96	0.11	2.71	440.0	3.43	90.0
822 120	3.04	3.40	0.11	3.15	500.0	4.01	65.5
822 620	3.64	4.00	0.11	3.75	620.0	4.80	45.2
822 760	3.89	4.25	0.11	4.00	649.0	5.13	39.4
822 783	4.14	4.50	0.15	4.25	870.0	5.45	81.0
822 800	4.89	5.25	0.15	5.00	1,100.0	6.45	58.1
822 801	6.13	6.50	0.15	6.25	1,370.0	8.09	36.6

Top panels -inside- (height 2.30 m)

Art. no.	l [m]	l _M [m]	t _{pl} [m]	l _c [m]	G / VP [kg]	A [m ²]	eh [kN/m ²]
822 065	1.89	2.25	0.11	2.00	530.0	4.35	176.0
822 155	2.60	2.96	0.11	2.71	660.0	5.98	90.0
822 180	3.04	3.40	0.11	3.15	740.0	6.99	65.5
822 680	3.64	4.00	0.11	3.75	850.0	8.37	45.2
822 780	3.89	4.25	0.11	4.00	980.0	8.95	39.4
822 785	4.14	4.50	0.15	4.25	1,435.0	9.50	81.0

Base panels -inside- reinforced (height 2.32 m)

Art. no.	l [m]	l _M [m]	t _{pl} [m]	l _c [m]	G / VP [kg]	A [m ²]	eh [kN/m ²]
821 249	3.04	3.40	0.15	3.15	985.0	7.05	154.4
821 248	3.64	4.00	0.15	3.75	1,165.0	8.44	106.5

Top panels -inside- reinforced (height 2.30 m)

Art. no.	l [m]	l _M [m]	t _{pl} [m]	l _c [m]	G / VP [kg]	A [m ²]	eh [kN/m ²]
822 181	3.04	3.40	0.15	3.15	1,080.0	6.99	154.4
822 182	3.64	4.00	0.15	3.75	1,260.0	8.37	106.5

Base panels -outside- (height 2.32 m)

Art. no.	l [m]	l _M [m]	t _{pl} [m]	l _c [m]	G / VP [kg]	A [m ²]	eh [kN/m ²]
821 150	2.00	2.25	0.11	2.00	542.0	4.64	149.0
821 170	2.71	2.96	0.11	2.71	675.0	6.29	80.0
821 310	3.15	3.40	0.11	3.15	755.0	7.31	59.0
821 770	3.75	4.00	0.11	3.75	865.0	8.70	41.4
821 910	4.00	4.25	0.11	4.00	990.0	9.28	36.3
821 913	4.25	4.50	0.15	4.25	1,313.0	9.86	75.0
821 912	5.00	5.25	0.15	5.00	1,545.0	11.60	54.5
821 916	6.25	6.50	0.15	6.25	1,910.0	14.50	34.7

Top panels -outside- (height 1.32 m)

Art. no.	l [m]	l _M [m]	t _{pl} [m]	l _c [m]	G / VP [kg]	A [m ²]	eh [kN/m ²]
822 075	2.00	2.25	0.11	2.00	365.0	2.64	149.0
821 190	2.71	2.96	0.11	2.71	455.0	3.58	80.0
822 310	3.15	3.40	0.11	3.15	510.0	4.16	59.0
822 710	3.75	4.00	0.11	3.75	585.0	4.95	41.4
822 810	4.00	4.25	0.11	4.00	647.0	5.28	36.3
822 813	4.25	4.50	0.15	4.25	900.0	5.61	75.0
822 815	5.00	5.25	0.15	5.00	1,115.0	6.60	54.5
822 830*	6.25	6.50	0.15	6.25	1,400.0	8.25	34.7

Possible height combinations

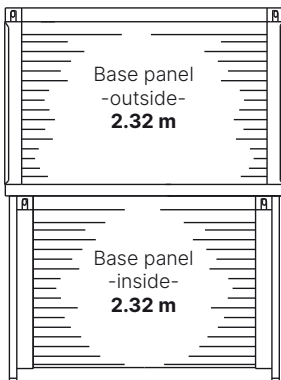

Shoring wall height approx. 4.60 m

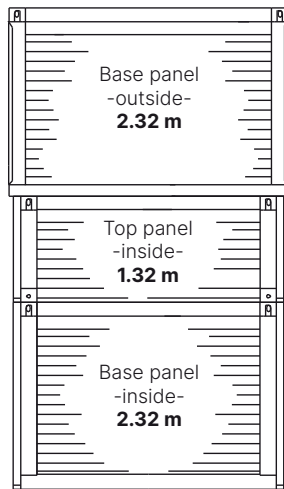

Shoring wall height approx. 6.00 m

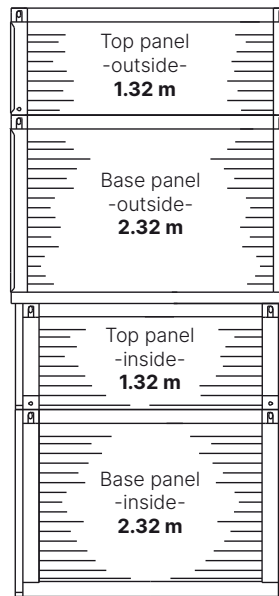

Shoring wall height approx. 7.30 m

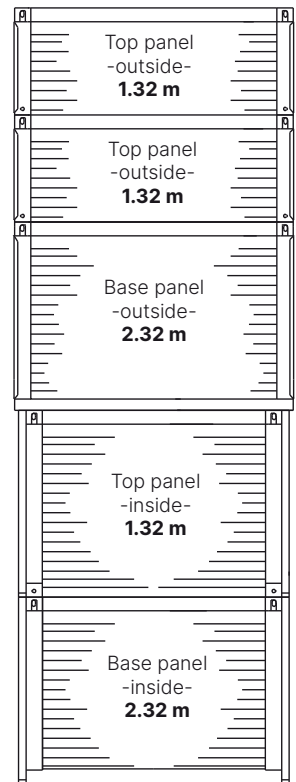

Shoring wall height approx. 9.60 m

Extension bars for rectangular strut cart

Art. no.	Short description	l [m]	G [kg]
830 005	HEB 220 extension bar	0.140	42.0
830 010	HEB 220 extension bar	0.275	50.0
830 011	HEB 220 extension bar	0.350	55.0
830 012	HEB 220 extension bar	0.375	62.0
830 015	HEB 220 extension bar	0.412	65.0
830 020	HEB 220 extension bar	0.550	70.0
830 030	HEB 220 extension bar	1.100	110.0
830 075	HEB 220 extension bar	1.650	145.0
830 125	HEB 220 extension bar	2.200	192.0
830 300	HEB 220 extension bar	3.300	278.0
830 305	HEB 220 extension bar	4.400	358.0

Extension bars for U-strut cart

Art. no.	Short description	l [m]	G [kg]
831 503	HEA 450 extension bar	0.140	77.0
831 500	HEA 450 extension bar	0.275	107.0
831 507	HEA 450 extension bar	0.375	115.0
831 510	HEA 450 extension bar	0.550	140.0
831 520	HEA 450 extension bar	1.100	220.0
831 530	HEA 450 extension bar	1.650	300.0
831 540	HEA 450 extension bar	2.200	375.0

Shoring widths for rectangular and U-strut cart

Extension bar length [m]	b _c [m]	b [m]
without extension bar	0.90	1.54
0.140	1.04	1.68
0.275	1.18	1.82
0.350	1.25	1.89
0.375	1.28	1.92
0.412	1.31	1.95
0.550	1.45	2.08
1.100	2.00	2.64
1.650	2.55	3.19
2.200	3.10	3.74
3.300	4.20	4.84
4.400	5.30	5.94

Other trench widths possible by combination of different extension bar lengths.

Accessories/spare parts

Art. no.	Short description	l [m]	d [m]	G [kg]
834 110	Cover top panel	1.00		9.9
834 100	Cover base panel	0.75		7.9
832 245	Linear shoring positioning bolts	0.30	0.040	4.0
832 230	Bolts, pressure panel, rectangular strut cart	0.15	0.035	1.4
861 076	Pressure beam	1.60		176.0
861 074	Pressure beam	2.35		236.0
861 070	Pressure beam	2.80		271.0
861 071	Pressure beam	3.40		318.0
861 075	Pressure beam	4.60		425.0
861 085	Pressure beam	5.80		525.0
834 015	Strut cart pressure panel			12.4
HE 0050 F	Spring connector 6.0 mm		0.006	0.03
IA 0150 F	Nut M 24–10.9 galv. (rectangular strut cart)			0.10
IA 0210 F	Nut M 36–10.9 galv. (U-strut cart)			0.40
862 200	Connector			5.5
862 100	Connector bolts	0.11	0.035	1.0
IB 0470 F	Screw M 24 × 80–10.9 galv. (rectangular strut cart)			0.40
IB 0614 F	Screw M 36 × 80–10.9 galv. (U-strut cart)			1.0
834 060	Pull adapter with bolts			43.6

l	Length	A	Surface	t _{pl}	Panel thickness	eh	Admissible soil pressure
l _M	Module length	G	Weight	b	Shoring width	b _c	Clear width
l _c	Pipe culvert length	G / VP	Weight / shoring panel	d	Diameter		

E+S Double slide rail inner-city linear shoring



General data

Module length	3.70 m
Slide-rail length	5.13 m / 6.13 m / 7.13 m / 8.13 m / 9.13 m
Piling frame element height	1.00 m
Pipe culvert height	variable
Sheet pile length (KD VI/8)	variable
Shoring width	variable

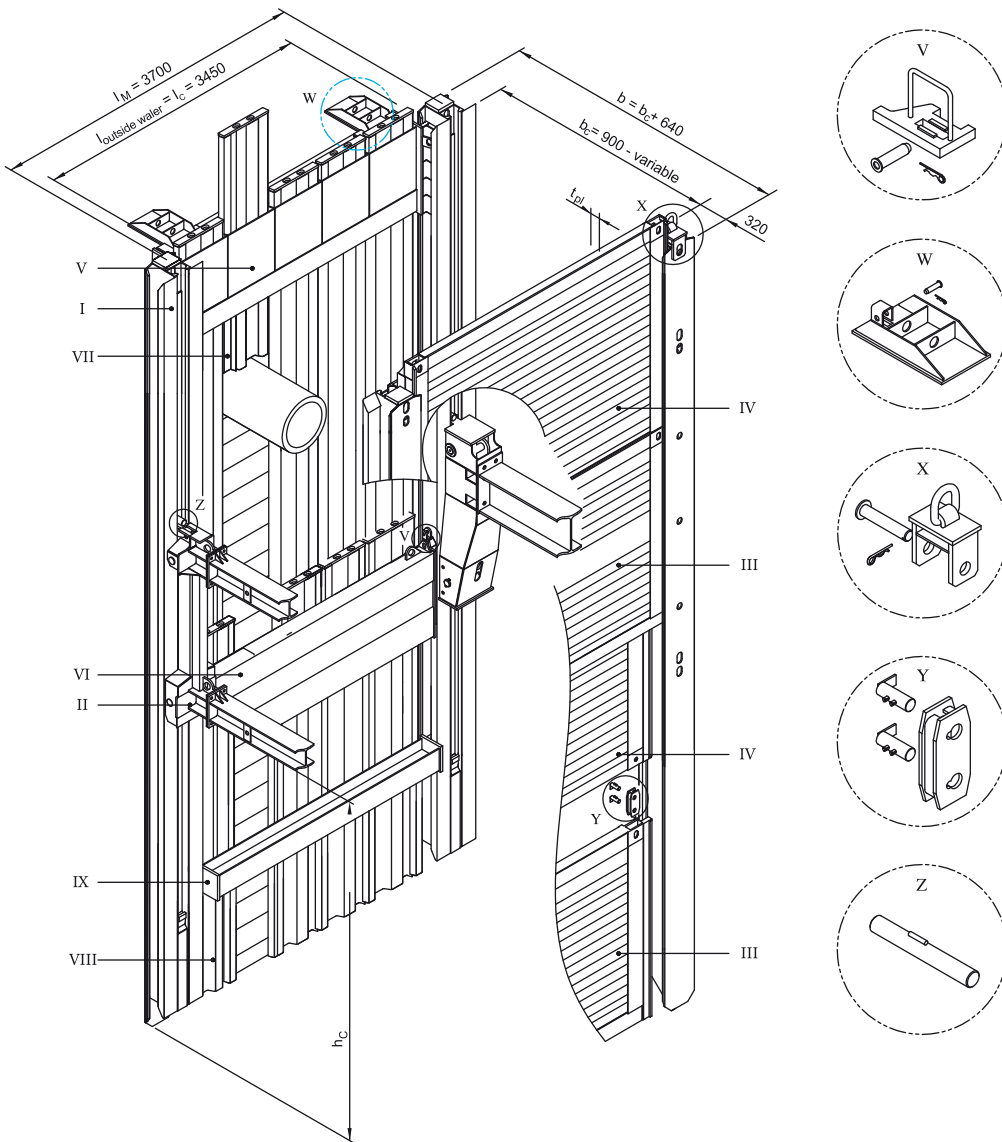

(All dimensions in mm. The data on pipe opening length l_c refer to the rectangular strut cart.)

- | | | | | | | | |
|-----|--------------------------------------|-------|--|----------|----------------------|---|-------------------------|
| I | Linear shoring support | VI | Piling frame element (inside water) | l_c | Pipe culvert length | V | Inside water anchoring |
| II | Linear shoring strut cart | VII | Sheet piles (outside water) | b | Shoring/trench width | W | Support bracket |
| III | Base panel | VIII | Sheet piles (inside water) | b_c | Clear width | X | Pull adapter with bolts |
| IV | Top panel | IX | Water support structure (inside water) | h_c | Pipe culvert height | Y | Connector with bolts |
| V | Piling frame element (outside water) | l_M | Module length | t_{pl} | Panel thickness | Z | Positioning bolt |

Linear shoring supports

Art. no.	Short description	l [m]	G [kg]
820 912	Linear shoring support	5.13	1,002.0
820 915	Linear shoring support	6.13	1,192.0
820 920	Linear shoring support	7.13	1,404.0
820 924	Linear shoring support	8.13	1,859.0
820 929	Linear shoring support	9.13	2,325.0

Linear shoring strut carts

Art. no.	Short description	l [m]	G [kg]
832 200	Rectangular strut cart	2.00	420.0
832 215	Rectangular strut cart with self-aligning roller, bottom	2.20	490.0
832 205	U-strut cart	2.00	618.0

Piling frame elements

Art. no.	Short description	l [m]	l _M [m]	t _{pl} [m]	l _c [m]	G / DKP [kg]
820 980	Piling frame element (outside waler)	3.45	3.70	0.30	3.45	1,330.0
821 000	Piling frame element (inside waler)	3.34	3.70	0.30	3.45	1,217.0

Base panels -outside- (height 2.32 m)

Art. no.	l [m]	l _M [m]	t _{pl} [m]	l _c [m]	G / VP [kg]	A [m ²]	eh [kN/m ²]
821 320	3.45	3.70	0.11	3.45	815.0	8.00	49.0

Top panels -inside- (height 1.32 m)

Art. no.	l [m]	l _M [m]	t _{pl} [m]	l _c [m]	G / VP [kg]	A [m ²]	eh [kN/m ²]
822 410	3.45	3.70	0.11	3.45	550.0	4.55	49.0

Base panels -inside- (height 2.32 m)

Art. no.	l [m]	l _M [m]	t _{pl} [m]	l _c [m]	G / VP [kg]	A [m ²]	eh [kN/m ²]
821 255	3.34	3.70	0.11	3.45	803.0	7.75	54.0

Top panels -inside-

Art. no.	l [m]	l _M [m]	h [m]	t _{pl} [m]	l _c [m]	G / VP [kg]	A [m ²]	eh [kN/m ²]
822 140	3.34	3.70	1.32	0.11	3.45	570.0	4.41	54.0
822 145	3.34	3.70	2.30	0.11	3.45	840.0	7.68	54.0

Walers, inner-city linear shoring

Art. no.	Short description	l [m]	l _M [m]	G/VP [kg]
821 002	Bracing for inside waler	3.30	3.70	310.0
821 003	Bracing for outside waler	3.46	3.70	374.0

Extension bars for rectangular strut cart

Art. no.	Short description	l [m]	G [kg]
830 005	HEB 220 extension bar	0.140	42.0
830 010	HEB 220 extension bar	0.275	50.0
830 011	HEB 220 extension bar	0.350	55.0
830 012	HEB 220 extension bar	0.375	62.0
830 015	HEB 220 extension bar	0.410	65.0
830 020	HEB 220 extension bar	0.550	70.0
830 030	HEB 220 extension bar	1.100	110.0
830 075	HEB 220 extension bar	1.650	145.0
830 125	HEB 220 extension bar	2.200	192.0
830 300	HEB 220 extension bar	3.300	278.0
830 305	HEB 220 extension bar	4.400	358.0

Extension bars for U-strut cart

Art. no.	Short description	l [m]	G [kg]
831 503	HEA 450 extension bar	0.140	77.0
831 500	HEA 450 extension bar	0.275	107.0
831 507	HEA 450 extension bar	0.375	115.0
831 510	HEA 450 extension bar	0.550	140.0
831 520	HEA 450 extension bar	1.100	220.0
831 530	HEA 450 extension bar	1.650	300.0
831 540	HEA 450 extension bar	2.200	375.0

Shoring widths for rectangular and U-strut cart

Extension bar length [m]	b _c [m]	b [m]
without extension bar	0.90	1.54
0.140	1.04	1.68
0.275	1.18	1.82
0.350	1.25	1.89
0.375	1.28	1.92
0.412	1.31	1.95
0.550	1.45	2.09
1.100	2.00	2.64
1.650	2.55	3.19
2.200	3.10	3.74
3.300	4.20	4.84
4.400	5.30	5.94

Other trench widths possible by combination of different extension bar lengths.

Accessories/spare parts

Art. no.	Short description	l [m]	d [m]	G [kg]
821 100	Chain 13/ 5,000 mm	5.00		25.7
834 110	Cover top panel	1.00		9.9
834 100	Cover base panel	0.75		7.9
832 245	Linear shoring positioning bolts	0.30	0.040	4.0
832 230	Bolts, pressure panel, rectangular strut cart	0.15	0.035	1.4
861 076	Pressure beam	1.60		176.0
861 074	Pressure beam	2.35		236.0
861 070	Pressure beam	2.80		271.0
861 071	Pressure beam	3.40		318.0
861 075	Pressure beam	4.60		425.0
861 085	Pressure beam	5.80		525.0
834 015	Strut cart pressure panel			12.4
HE 0050 F	Spring connector 6.0 mm		0.006	0.03
336 920	Inside waler anchoring R/L + DK LV bolt			6.00
336 960	Support brackets for piling frame element incl. bolts and spring connector			40.0
IA 0150 F	Nut M 24–10.9 galv. (rectangular strut cart)			0.10
IA 0210 F	Nut M 36–10.9 galv. (U-strut cart)			0.40
862 200	Connector			5.5
862 100	Connector bolts	0.11	0.035	1.0
IB 0470 F	Screw M 24 × 80–10.9 galv. (rectangular strut cart)			0.40
IB 0614 F	Screw M 36 × 80–10.9 galv. (U-strut cart)			1.0
834 060	Pull adapter with bolts			43.6

l	Length	A	Surface	t _{pl}	Panel thickness	eh	Admissible soil pressure
l _M	Module length	G	Weight	b	Shoring width	b _c	Clear width
l _c	Pipe culvert length	G / VP	Weight / shoring panel	d	Diameter	G / DKP	Weight / sheet piling element
h	Panel height						

E+S Double slide rail corner shoring



General data

Module length	2.25 m–6.50 m
Slide-rail length	5.13 m / 6.13 m
Panel height	1.32 m / 2.32 m
Shoring width	1.75 m–6.00 m

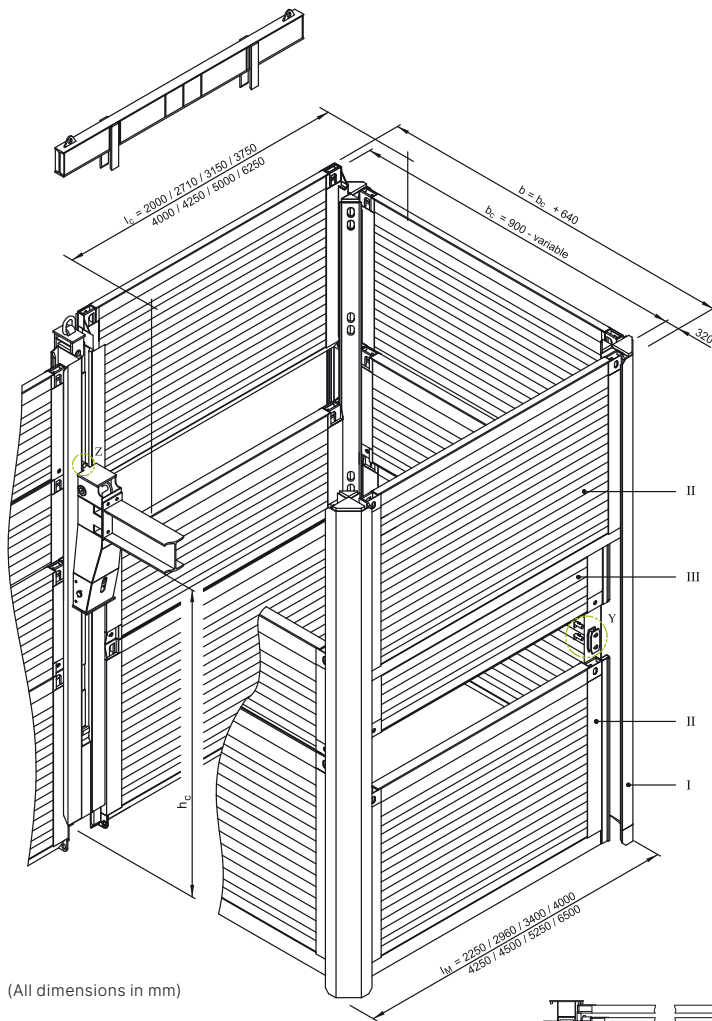

(All dimensions in mm)

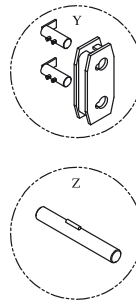

- I Corner shoring support
- II Base panel
- III Top panel
- l_M Module length
- l_c Pipe culvert length
- b Shoring/trench width
- b_c Clear width
- h_c Pipe culvert height
- $l_{zWSt.}$ Extension bar length
- l_A Trench width
- Y Connector with bolts
- Z Positioning bolt

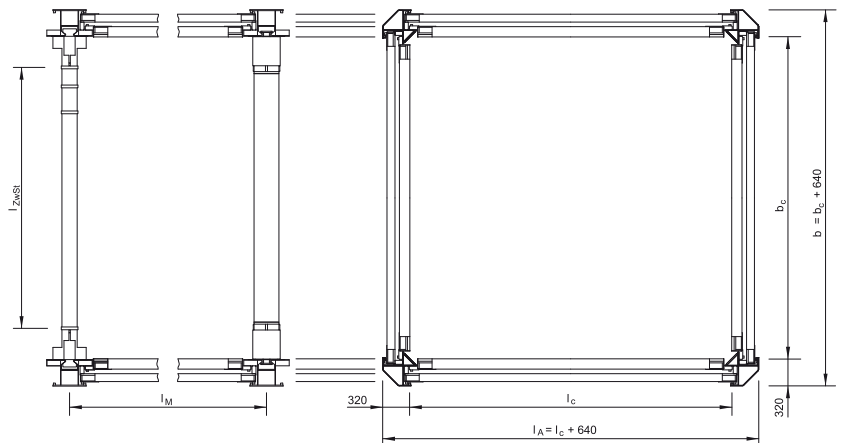

Linear shoring supports

Art. no.	Short description	l [m]	G [kg]
835 100	Corner shoring support	5.13	740.0
835 120	Corner shoring support	6.13	900.0

Base panels -inside- (height 2.32 m)

Art. no.	l [m]	l _M [m]	t _{pl} [m]	l _c [m]	G / VP [kg]	A [m ²]	eh [kN/m ²]
821 120	1.89	2.25	0.11	2.00	510.0	4.38	176.0
821 160	2.60	2.96	0.11	2.71	650.0	6.03	90.0
821 250	3.04	3.40	0.11	3.15	730.0	7.05	65.5
821 610	3.64	4.00	0.11	3.75	845.0	8.44	45.2
821 850	3.89	4.25	0.11	4.00	970.0	9.02	39.4
821 855	4.14	4.50	0.15	4.25	1,300.0	9.58	81.0
821 860	4.89	5.25	0.15	5.00	1,500.0	11.34	58.1
821 861	6.13	6.50	0.15	6.25	1,880.0	14.22	36.6

Top panels -inside- (height 1.32 m)

Art. no.	l [m]	l _M [m]	t _{pl} [m]	l _c [m]	G / VP [kg]	A [m ²]	eh [kN/m ²]
822 060	1.89	2.25	0.11	2.00	355.0	2.49	176.0
821 180	2.60	2.96	0.11	2.71	440.0	3.43	90.0
822 120	3.04	3.40	0.11	3.15	500.0	4.01	65.5
822 620	3.64	4.00	0.11	3.75	620.0	4.80	45.2
822 760	3.89	4.25	0.11	4.00	649.0	5.13	39.4
822 783	4.14	4.50	0.15	4.25	870.0	5.45	81.0
822 800	4.89	5.25	0.15	5.00	1,100.0	6.45	58.1
822 801	6.13	6.50	0.15	6.25	1,370.0	8.09	36.6

Top panels -inside- (height 2.30 m)

Art. no.	l [m]	l _M [m]	t _{pl} [m]	l _c [m]	G / VP [kg]	A [m ²]	eh [kN/m ²]
822 065	1.89	2.25	0.11	2.00	530.0	4.35	176.0
822 155	2.60	2.96	0.11	2.71	660.0	5.98	90.0
822 180	3.04	3.40	0.11	3.15	740.0	6.99	65.5
822 680	3.64	4.00	0.11	3.75	850.0	8.37	45.2
822 780	3.89	4.25	0.11	4.00	980.0	8.95	39.4
822 785	4.14	4.50	0.15	4.25	1,435.0	9.50	81.0

Base panels -outside- (height 2.32 m)

Art. no.	l [m]	l _M [m]	t _{pl} [m]	l _c [m]	G / VP [kg]	A [m ²]	eh [kN/m ²]
821 150	2.00	2.25	0.11	2.00	542.0	4.64	149.0
821 170	2.71	2.96	0.11	2.71	675.0	6.29	80.0
821 310	3.15	3.40	0.11	3.15	755.0	7.31	59.0
821 770	3.75	4.00	0.11	3.75	865.0	8.70	41.4
821 910	4.00	4.25	0.11	4.00	990.0	9.28	36.3
821 913	4.25	4.50	0.15	4.25	1,313.0	9.86	75.0
821 912	5.00	5.25	0.15	5.00	1,545.0	11.60	54.5
821 916	6.25	6.50	0.15	6.25	1,910.0	14.50	34.7

Top panels -outside- (height 1.32 m)

Art. no.	l [m]	l _M [m]	t _{pl} [m]	l _c [m]	G / VP [kg]	A [m ²]	eh [kN/m ²]
822 075	2.00	2.25	0.11	2.00	365.0	2.64	149.0
821 190	2.71	2.96	0.11	2.71	455.0	3.58	80.0
822 310	3.15	3.40	0.11	3.15	510.0	4.16	59.0
822 710	3.75	4.00	0.11	3.75	585.0	4.95	41.4
822 810	4.00	4.25	0.11	4.00	647.0	5.28	36.3
822 813	4.25	4.50	0.15	4.25	900.0	5.61	75.0
822 815	5.00	5.25	0.15	5.00	1,115.0	6.60	54.5
822 830	6.25	6.50	0.15	6.25	1,400.0	8.25	34.7

Installation options

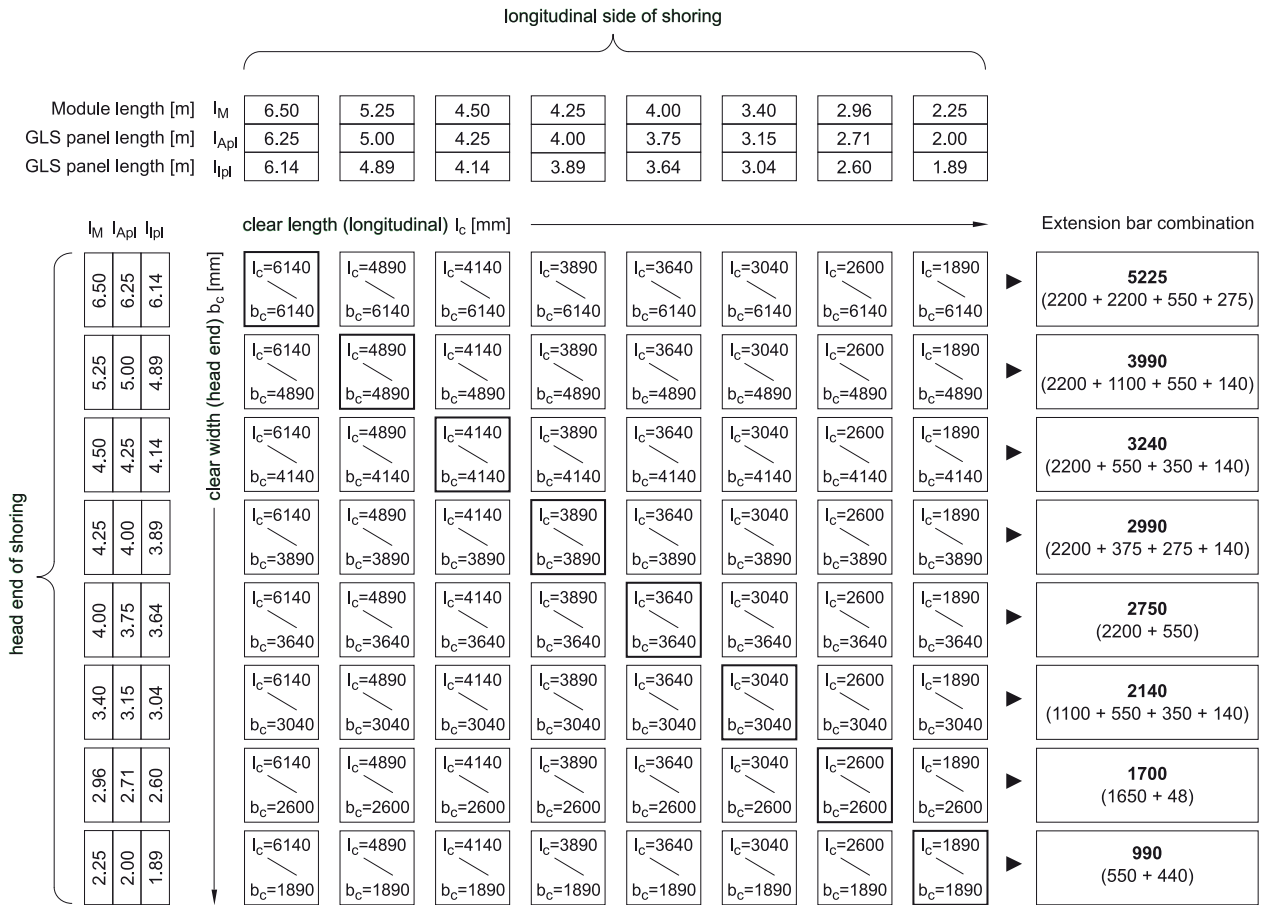

Example: Top end shoring module length $I_M = 3.40$ m
 Required extension bar combinations for strut cart in linear shoring field: 2,140 mm

Accessories/spare parts

Art. no.	Short description	l [m]	d [m]	G [kg]
834 110	Cover top panel	1.00		9.9
834 100	Cover base panel	0.75		7.9
861 076	Pressure beam	1.60		176.0
861 074	Pressure beam	2.35		236.0
861 070	Pressure beam	2.80		271.0
861 071	Pressure beam	3.40		318.0
861 075	Pressure beam	4.60		425.0
861 085	Pressure beam	5.80		525.0
834 015	Strut cart pressure panel			12.4
862 200	Connector			5.5
862 100	Connector bolts	0.11	0.035	1.0

l	Length	I_{Apl}	Outside panel length	G	Weight	d	Diameter
I_M	Module length	I_{Ipl}	Inside panel length	G / VP	Weight / shoring panel	eh	Admissible soil pressure
I_c	Pipe culvert length	A	Surface	t_{pl}	Panel thickness		

E+S Deep linear shoring

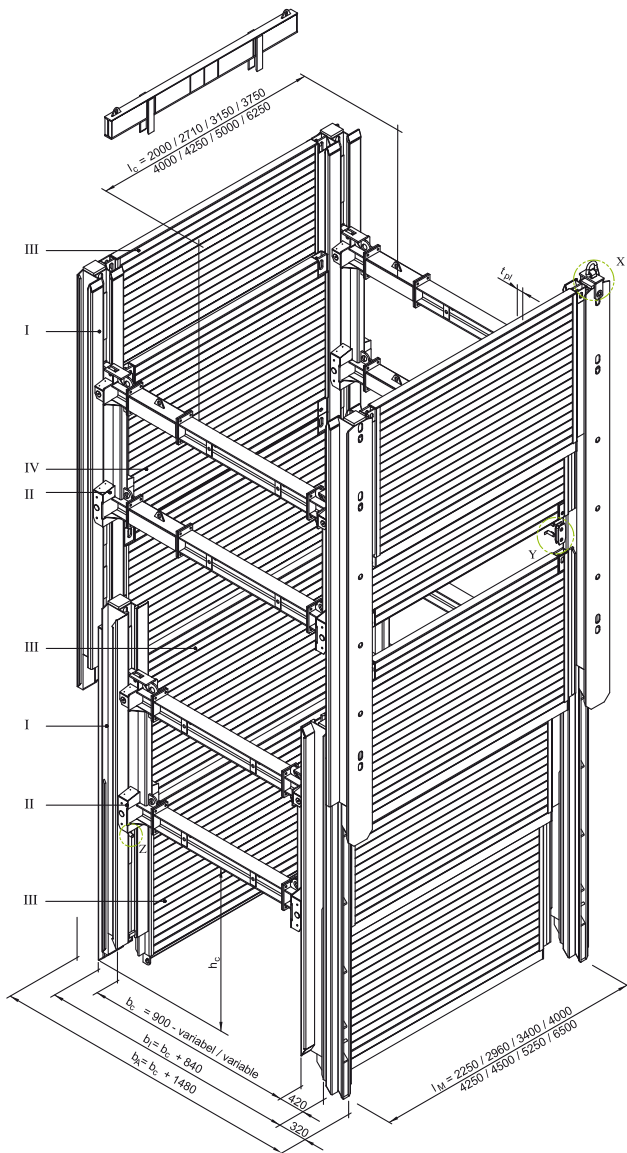
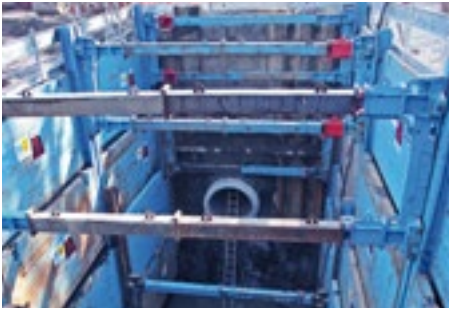

General data

Module length	2.25 m–6.50 m
Slide-rail length	variable
Panel height	1.32 m / 2.32 m
Pipe culvert height	variable
Shoring width	variable

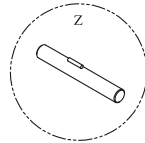
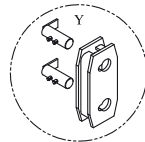
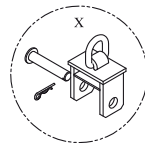
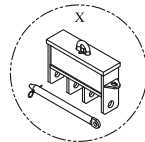

- I Linear shoring support
- II Linear shoring strut cart
- III Base panel
- IV Top panel
- l_m Module length
- l_c Pipe culvert length
- b_A Shoring/trench width (outside rail)
- b_I Shoring/trench width (inside rail)
- b_c Clear width
- h_c Pipe culvert height
- t_{pi} Panel thickness
- X Pull adapter with bolts
- Y Connector with bolts
- Z Positioning bolt

(All dimensions in mm. The data on pipe opening length l_c refer to the rectangular strut cart.)

Linear shoring supports

Art. no.	Short description	l [m]	G [kg]
820 952	Linear shoring support -inside-	5.13	1,189.0
820 947	Linear shoring support -outside-	6.13	1,260.0
820 948	Linear shoring support -inside-	6.13	1,409.0
820 953	Linear shoring support -outside-	7.13	1,470.0

Linear shoring strut cart

Art. no.	Short description	l [m]	G [kg]
832 215	Rectangular strut cart with self-aligning roller, bottom	2.20	490.0

Base panels -inside- (height 2.32 m)

Art. no.	l [m]	l _M [m]	t _{pl} [m]	l _c [m]	G / VP [kg]	A [m ²]	eh [kN/m ²]
821 120	1.89	2.25	0.11	2.00	510.0	4.38	176.0
821 160	2.60	2.96	0.11	2.71	650.0	6.03	90.0
821 250	3.04	3.40	0.11	3.15	730.0	7.05	65.5
821 610	3.64	4.00	0.11	3.75	845.0	8.44	45.2
821 850	3.89	4.25	0.11	4.00	970.0	9.02	39.4
821 855	4.14	4.50	0.15	4.25	1,300.0	9.58	81.0
821 860	4.89	5.25	0.15	5.00	1,500.0	11.34	58.1
821 861	6.13	6.50	0.15	6.25	1,880.0	14.22	36.6

Top panels -inside- (height 1.32 m)

Art. no.	l [m]	l _M [m]	t _{pl} [m]	l _c [m]	G / VP [kg]	A [m ²]	eh [kN/m ²]
822 060	1.89	2.25	0.11	2.00	355.0	2.49	176.0
821 180	2.60	2.96	0.11	2.71	440.0	3.43	90.0
822 120	3.04	3.40	0.11	3.15	500.0	4.01	65.5
822 620	3.64	4.00	0.11	3.75	620.0	4.80	45.2
822 760	3.89	4.25	0.11	4.00	649.0	5.13	39.4
822 783	4.14	4.50	0.15	4.25	870.0	5.45	81.0
822 800	4.89	5.25	0.15	5.00	1,100.0	6.45	58.1
822 801	6.13	6.50	0.15	6.25	1,370.0	8.09	36.6

Top panels -inside- (height 2.30 m)

Art. no.	l [m]	l _M [m]	t _{pl} [m]	l _c [m]	G / VP [kg]	A [m ²]	eh [kN/m ²]
822 065	1.89	2.25	0.11	2.00	530.0	4.35	176.0
822 155	2.60	2.96	0.11	2.71	660.0	5.98	90.0
822 180	3.04	3.40	0.11	3.15	740.0	6.99	65.5
822 680	3.64	4.00	0.11	3.75	850.0	8.37	45.2
822 780	3.89	4.25	0.11	4.00	980.0	8.95	39.4
822 785	4.14	4.50	0.15	4.25	1,435.0	9.50	81.0

Base panels -outside- (height 2.32 m)

Art. no.	l [m]	l _M [m]	t _{pl} [m]	l _c [m]	G / VP [kg]	A [m ²]	eh [kN/m ²]
821 150	2.00	2.25	0.11	2.00	542.0	4.64	149.0
821 170	2.71	2.96	0.11	2.71	675.0	6.29	80.0
821 310	3.15	3.40	0.11	3.15	755.0	7.31	59.0
821 770	3.75	4.00	0.11	3.75	865.0	8.70	41.4
821 910	4.00	4.25	0.11	4.00	990.0	9.28	36.3
821 913	4.25	4.50	0.15	4.25	1,313.0	9.86	75.0
821 912	5.00	5.25	0.15	5.00	1,545.0	11.60	54.5
821 916	6.25	6.50	0.15	6.25	1,910.0	14.50	34.7

Top panels -outside- (height 1.32 m)

Art. no.	l [m]	l _M [m]	t _{pl} [m]	l _c [m]	G / VP [kg]	A [m ²]	eh [kN/m ²]
822 075	2.00	2.25	0.11	2.00	365.0	2.64	149.0
821 190	2.71	2.96	0.11	2.71	455.0	3.58	80.0
822 310	3.15	3.40	0.11	3.15	510.0	4.16	59.0
822 710	3.75	4.00	0.11	3.75	585.0	4.95	41.4
822 810	4.00	4.25	0.11	4.00	647.0	5.28	36.3
822 813	4.25	4.50	0.15	4.25	900.0	5.61	75.0
822 815	5.00	5.25	0.15	5.00	1,115.0	6.60	54.5
822 830	6.25	6.50	0.15	6.25	1,400.0	8.25	34.7

Extension bars for rectangular strut cart

Art. no.	Short description	l [m]	G [kg]
830 010	HEB 220 extension bar	0.275	50.0
830 020	HEB 220 extension bar	0.550	70.0
830 027	HEB 220 extension bar (upper shoring field)	0.840	134.0
830 030	HEB 220 extension bar	1.100	110.0
830 075	HEB 220 extension bar	1.650	145.0
830 125	HEB 220 extension bar	2.200	192.0

Shoring widths, deep linear shoring

Extension bar length [m]	b _c [m]	b _i [m]	b _A [m]
without extension bar		0.900	1.28
0.275	1.175	2.015	2.655
0.550	1.450	2.290	2.930
1.100	2.000	2.840	3.480
1.650	2.550	3.390	4.030
2.200	3.100	3.940	4.580

Other trench widths possible by combination of different extension bar lengths.

Accessories/spare parts

Art. no.	Short description	l [m]	d [m]	G [kg]
832 245	Linear shoring positioning bolts	0.30	0.040	3.2
832 230	Bolts, pressure panel, rectangular strut cart	0.15	0.035	1.4
861 076	Pressure beam	1.60		176.0
861 074	Pressure beam	2.35		236.0
861 070	Pressure beam	2.80		271.0
861 071	Pressure beam	3.40		318.0
861 075	Pressure beam	4.60		425.0
861 085	Pressure beam	5.80		525.0
834 015	Strut cart pressure panel (single, double slide rail)			12.4
HE 0050 F	Spring connector 6.0 mm		0.006	0.03
IA 0150 F	Nut M 24–10.9 galv. (rectangular strut cart)			0.10
862 200	Connector			5.5
862 100	Connector bolts	0.11	0.035	1.0
IB 0470 F	Screw M 24 × 80–10.9 galv. (rectangular strut cart)			0.40
834 060	Pull adapter with bolts			43.6
832 261	TLV pressure adapter with bolts			180.0

l	Length	b	Shoring width	A	Surface	eh	Admissible soil pressure
l _M	Module length	d	Diameter	G	Weight	b _c	Clear width
l _c	Pipe culvert length	b _i	Shoring/trench width (inside rail)	G / VP	Weight / shoring panel	b _A	Shoring/trench width (outside rail)
t _{pl}	Panel thickness						

E+S Head end shoring with sheet piles

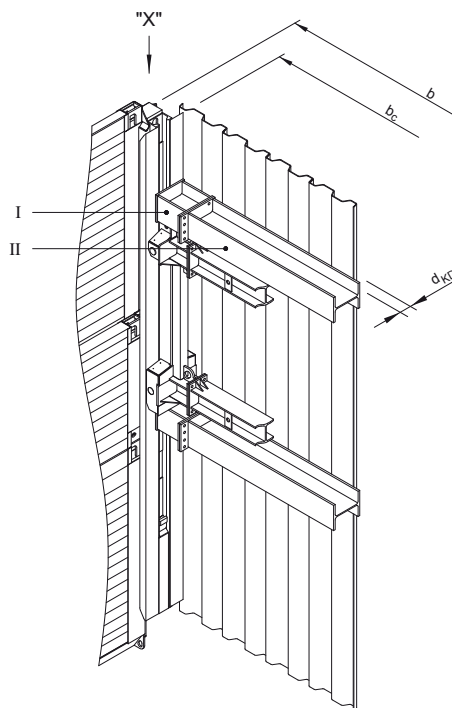

- I Adapter for trench end shoring
- II Extension bars
- b Shoring/trench width
- b_c Clear width
- d_{kp} Sheet pile thickness

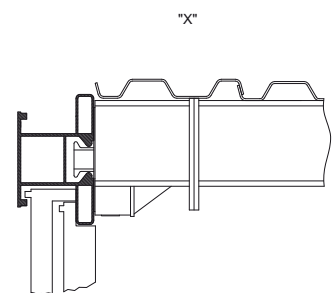

Head end shoring adapter with sheet piles

Art. no.	Short description	l [m]	G [kg]
899 994	Head end shoring adapter	0.45	132.0

Extension bars for head end shoring

Art. no.	Short description	l [m]	b_c [m]	G [kg]
830 801	HEA 360 extension bar	0.140	1.04	70.0
830 802	HEA 360 extension bar	0.275	1.18	85.0
830 803	HEA 360 extension bar	0.375	1.28	97.0
830 804	HEA 360 extension bar	0.412	1.32	100.0
830 800	HEA 360 extension bar	0.550	1.45	114.0
830 806	HEA 360 extension bar	1.100	2.00	175.0
830 810	HEA 360 extension bar	1.650	2.55	240.0
830 830	HEA 360 extension bar	2.200	3.10	304.0
830 833	HEA 360 extension bar	2.480	3.38	340.0
830 836	HEA 360 extension bar	3.300	4.20	436.0
830 840	HEA 360 extension bar	3.580	4.48	468.0
830 850	HEA 360 extension bar	4.400	5.30	561.0
830 855	HEA 360 extension bar	4.950	5.85	626.0
830 857	HEA 360 extension bar	5.500	6.40	693.0
830 860	HEA 360 extension bar	6.050	6.95	758.0

Accessories/spare parts

Art. no.	Short description	l [m]	d [m]	G [kg]
IB 0470F	Screw M 24 × 80–10.9 galv.			0.40
IA 0150F	Nut M 24–10.0			0.10
821 100	Chain 13/ 5,000 mm	5.00		25.7

l Length

G Weight

 b_c Clear width

d Diameter

E+S Head end shoring with slide-rail panels

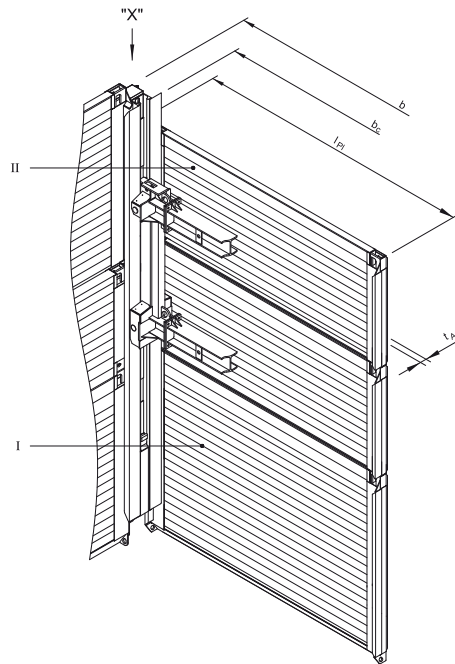

- I Base panel
- II Top panel
- l_{pi} Panel length
- b Shoring/trench width
- b_c Clear width
- t_{Apl} Outside panel thickness

Base panels -outside- (height 2.32 m)

Art. no.	l [m]	l_M [m]	t_{pi} [m]	l_c [m]	G / VP [kg]	A [m ²]	eh [kN/m ²]
821 150	2.00	2.25	0.11	2.00	542.0	4.64	149.0
821 170	2.71	2.96	0.11	2.71	675.0	6.29	80.0
821 310	3.15	3.40	0.11	3.15	755.0	7.31	59.0
821 770	3.75	4.00	0.11	3.75	865.0	8.70	41.4
821 910	4.00	4.25	0.11	4.00	990.0	9.28	36.3
821 913	4.25	4.50	0.15	4.25	1,313.0	9.86	75.0
821 912	5.00	5.25	0.15	5.00	1,545.0	11.60	54.5
821 916	6.25	6.50	0.15	6.25	1,910.0	14.50	34.7

Top panels -outside- (height 1.32 m)

Art. no.	l [m]	l_M [m]	t_{pi} [m]	l_c [m]	G / VP [kg]	A [m ²]	eh [kN/m ²]
822 075	2.00	2.25	0.11	2.00	365.0	2.64	149.0
821 190	2.71	2.96	0.11	2.71	455.0	3.58	80.0
822 310	3.15	3.40	0.11	3.15	510.0	4.16	59.0
822 710	3.75	4.00	0.11	3.75	585.0	4.95	41.4
822 810	4.00	4.25	0.11	4.00	647.0	5.28	36.3
822 813	4.25	4.50	0.15	4.25	900.0	5.61	75.0
822 815	5.00	5.25	0.15	5.00	1,115.0	6.60	54.5
822 830 *	6.25	6.50	0.15	6.25	1,400.0	8.25	34.7

Shoring widths

Art. no.	l_{pi} [m]	l_M [m]	min. b_c [m]	Extension bar combination	
				min. b_c [mm]	max. b_c [mm]
821 150	2.00	2.25	1.49	2 × 20 / 550	1.73
821 170	2.71	2.96	2.18	2 × 20 / 140 / 1,100	2.41
821 310	3.15	3.40	2.69	140 / 1,650	2.83
821 770	3.75	4.00	3.24	140 / 2,200	3.48
821 910	4.00	4.25	3.48	375 / 2,200	3.75
821 913	4.25	4.50	3.79	140 / 550 / 2,200	3.93
821 912	5.00	5.25	4.48	275 / 1,100 / 2,200	4.61

Accessories/spare parts

Art. no.	Short description	l [m]	d [m]	G [kg]
862 200	Connector			5.5
862 100	Connector bolts	0.11	0.035	1.0

- l Length
- l_M Module length
- l_c Pipe culvert length
- t_{pi} Panel thickness
- d Diameter
- A Surface
- G Weight
- G / VP Weight / shoring panel
- eh Admissible soil pressure
- b_c Clear width
- l_{pi} Panel length

E+S Head end shoring with head end strut cart and sheet piles

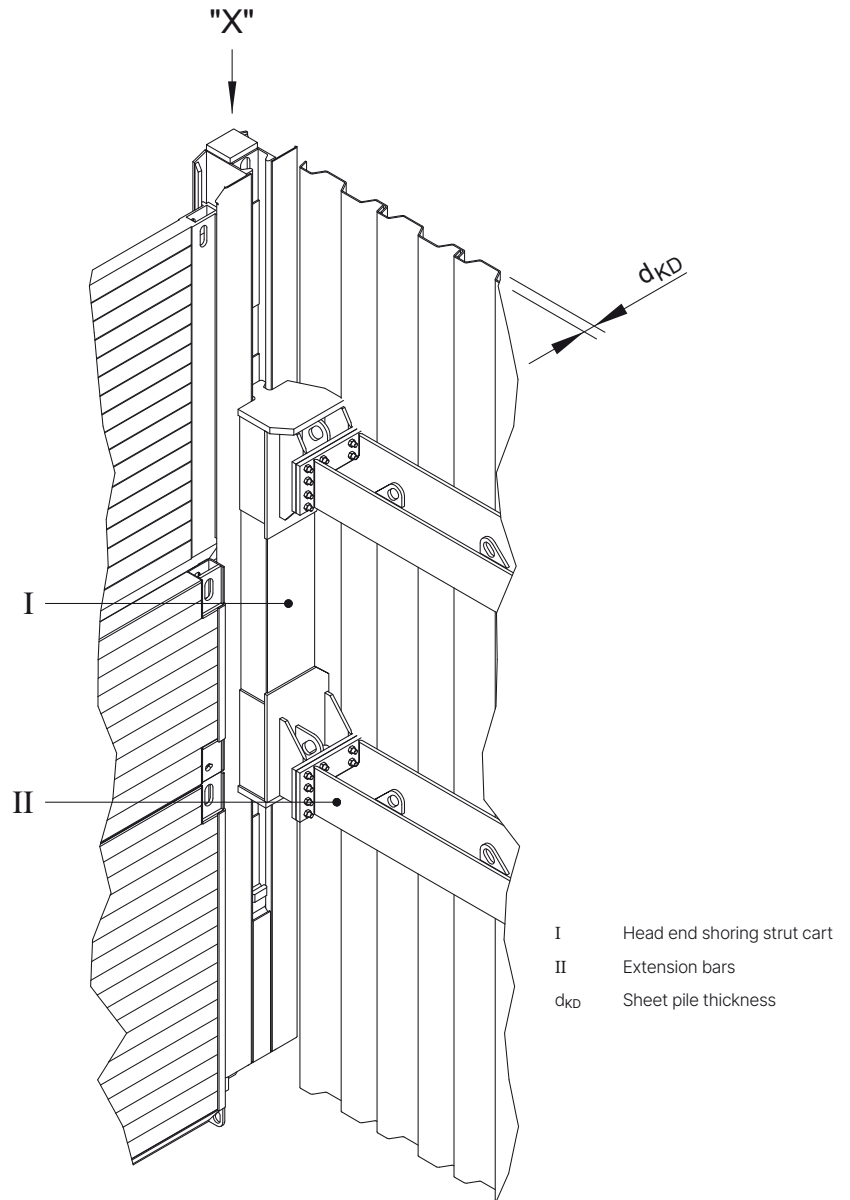
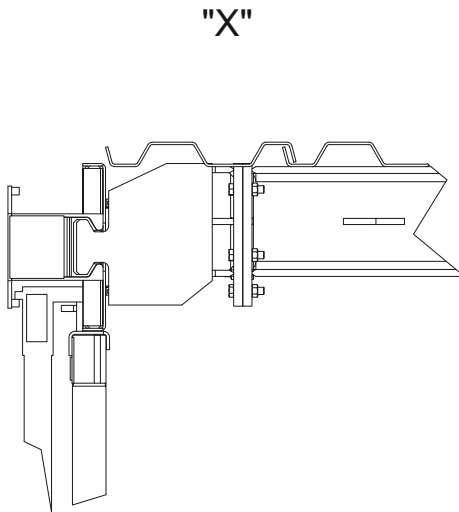

Head end shoring strut cart

Art. no.	Short description	I [m]	G [kg]
832 199	Head end shoring strut cart, E+S R/L	2.50	820.0

Extension bars, head end shoring strut cart

Art. no.	Short description	I [m]	b _c [m]	G [kg]
836 090	HEB 360 extension bar	0.275	1.175	105.0
836 093	HEB 360 extension bar	0.550	1.450	150.0
836 095	HEB 360 extension bar	1.100	2.000	230.0
836 097	HEB 360 extension bar	1.650	2.550	310.0
836 100	HEB 360 extension bar	2.200	3.100	385.0
836 105	HEB 360 extension bar	3.300	4.200	543.0

Accessories/spare parts

Art. no.	Short description	G [kg]
IB 0512F	Screw M24×100-10.9 galv.	0.50
IA 0150F	Nut M24-10.0 galv	0.10

I Length

G Weight

b_c Clear width

E+S Outside waler attachment



A: M36 outside waler attachment
Fixed position

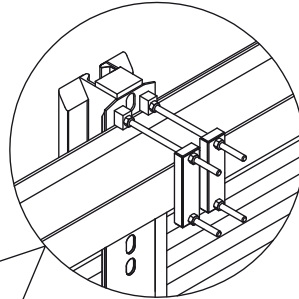

B: GEWI outside waler attachment
Vertically adjustable position

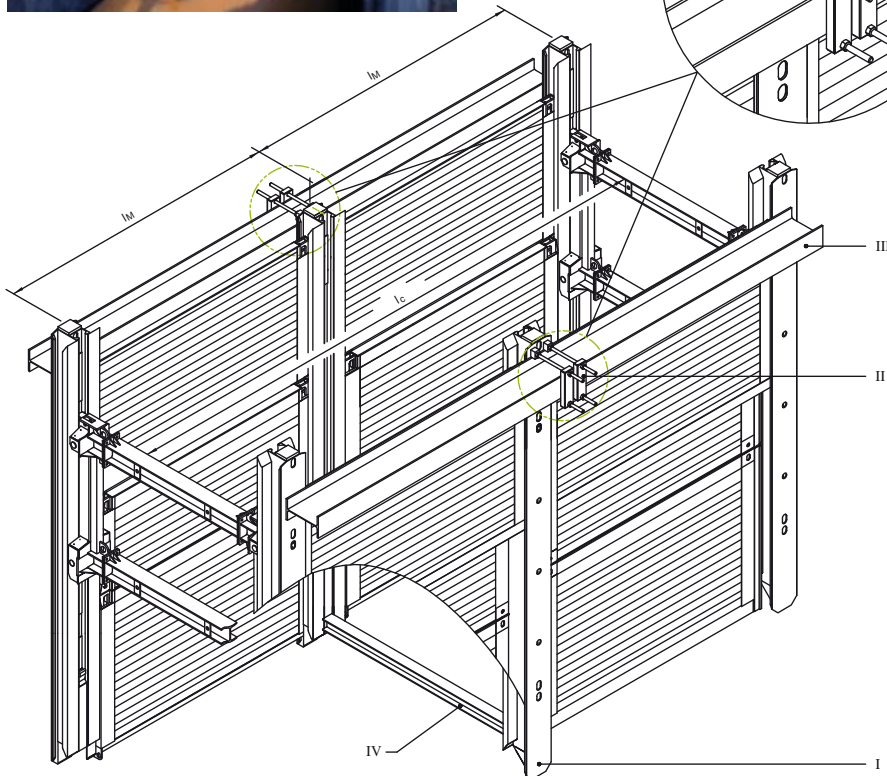
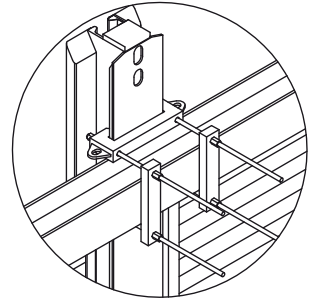

- | | | | | | |
|-----|--------------------------|-------|---------------------|------|---|
| I | Linear shoring support | l_M | Module length | A | M 36 outside waler attachment, fixed position, for linear shoring |
| II | Outside waler attachment | l_c | Pipe culvert length | B | GEWI outside waler attachment for linear and parallel shoring, vertically adjustable position, for linear shoring |
| III | Waler support | G | Weight | DGLV | Double slide rail, linear shoring |
| IV | Bottom end support | | | EGLV | Single slide rail, linear shoring |

M36 outer waler attachment

Art. no.	Short description	G [kg]
855 836	M36 waler attachment for HEB brackets up to HEB 600	80.0
855 846	M36 waler attachment for HEB brackets from HEB 650 to HEB 800	86.5

GEWI outside waler attachment

Art. no.	Short description	G [kg]
855 838	GEWI waler attachment for HEB brackets up to HEB 600/DGLV	162.0
855 841	GEWI waler attachment for HEB brackets up to HEB 1000/DGLV	169.0
855 839	GEWI waler attachment for linear shoring support/DGLV	195.0
855 881	GEWI waler attachment for HEB brackets up to HEB 600/EGLV	170.0
855 882	GEWI waler attachment for HEB brackets up to HEB 1000/EGLV	175.0
855 880	GEWI waler attachment for linear shoring support/EGLV	200.0

Steel site road



General data

Length	2,340 mm
Width	3,800 mm
Height	160 mm
Weight	869 kg
Surface	8.892 m ²
Load	12 t axle load

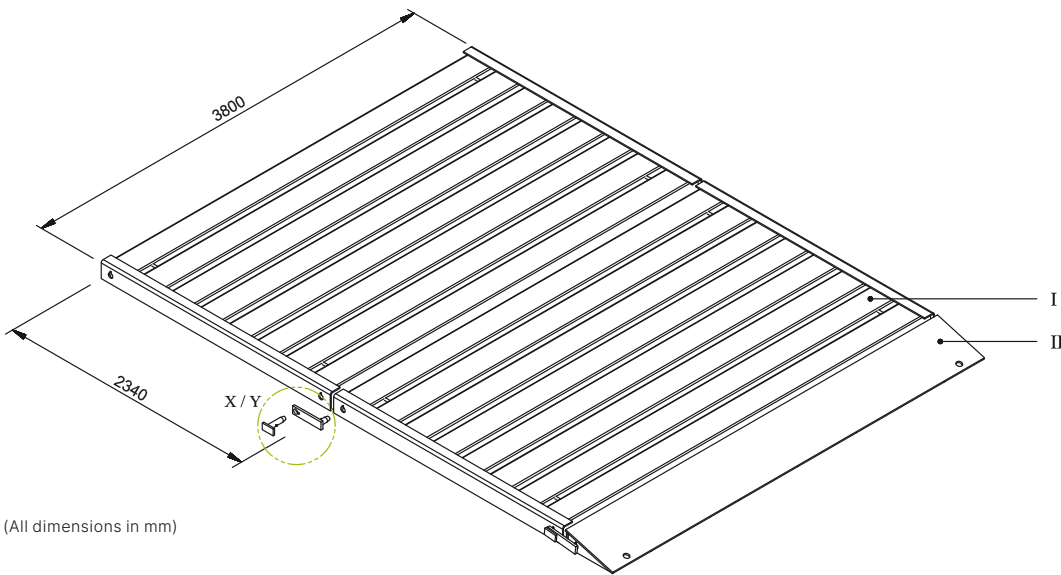

(All dimensions in mm)

- I Steel site road
- II Access ramp
- X Connector
- Y Bolt

Accessories/spare parts

Art. no.	Short description	l [m]	b [m]	A [m ²]	G [kg]
880 100	Steel site road	2.34	3.80	8.89	869.0
880 150	Connector				4.8
880 200	Access ramp	0.48	3.80	1.82	334.0
852 350	Chain, 4-strand	3.00			55.6
880 152	Bolt				3.4

I Length

A Surface

b_c Clear width

G Weight

Plastic site road



General data

Material	Polyethylene with high density
Dimensions	3,000 mm × 2,500 mm × 47 mm
Weight	295 kg / panel
Dimensions	3,000 mm × 2,400 mm × 45.5 mm
Weight	285 kg / panel
Surface	Profile on both sides
Load capacity	approx. 160 t/m ² (depending on sub-surface)
Transport	75 panels / truck

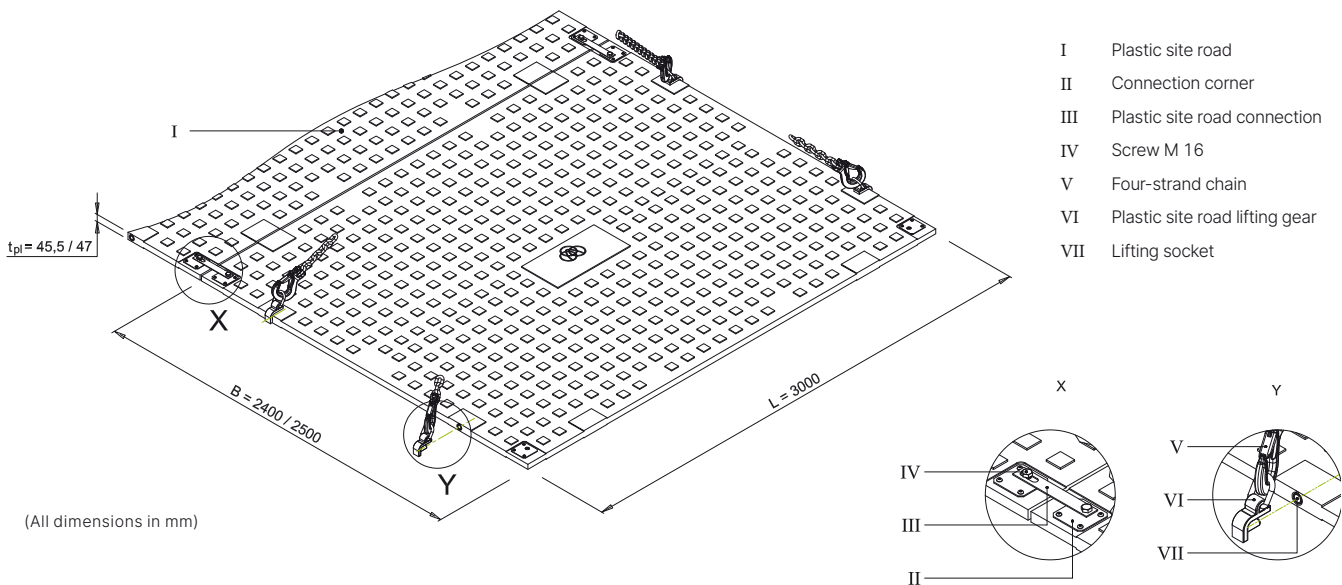

Panels

Art. no.	Short description	l [m]	b [m]	t _{pi} [m]	A [m ²]	G [kg]
880 224	Plastic site road 3.00 × 2.40 m	3.00	2.40	0.046	7.20	285.0
880 225 tk	Plastic site road 3.00 × 2.50 m	3.00	2.50	0.047	7.50	295.0

Accessories/spare parts

Art. no.	Short description	l [m]	b [m]	d [m]	G [kg]
880 239	Plastic site road connection, 2-fold, metal	0.26	0.04	0.005	0.58
IB 0250F	Screw M16 × 30	0.03		0.016	0.15
852 357	Four-strand chain	3.50		0.013	60.0
880 250	Plastic site road lifting gear				1.15
300 077	Corner top unit connection incl. threaded sleeve				0.31
CC 1188 E	Corner bottom unit connection				0.24
IA 0035 F	M8 sleeve nut				-
IC 0111 F	M8 fillister head screw				-
IA 0036 F	Stop sleeve				-

l Length
b Breite

d Diameter
A Surface

t_{pi} Panel thickness

G Weight

SZ 10 pipe puller



General data

Traction	100 kN (observe friction values)
Pulling length	70 m
Working travel (lift)	500 mm
Engine	1.3 kW-2,400 rpm-12 V
Pipe diameter	800 mm-2,400 mm
Cable	20 m-70 m
Power supply (battery)	12 V / 170 Ah
Working pressure	160 bar

Accessories/spare parts

Art. no.	Short description	l [m]	d [m]	G [kg]
138 030	Bolt 125 × 20	0.125	0.020	0.4
138 200	Spring connector FS 92 × 5	0.092	0.005	0.1
284 010	Pipe puller, SZ remote control-SZ 10			456.0
139 380	Extension pipe ZW SB-108 × 100	0.10		5.5
139 415	Extension pipe ZW SB-108 × 200	0.20		10.0
139 430	Extension pipe ZW SB-108 × 300	0.30		13.8
139 445	Extension pipe ZW SB-108 × 500	0.50		17.7
139 385	Extension pipe ZW SB-108 × 1,000	1.00		28.0
139 400	Extension pipe ZW SB-108 × 1,500	1.50		37.5
284 830	Cable 35 m, Ø 18 mm	35.00	0.018	67.0
284 850	Cable 50 m, Ø 18 mm	50.00	0.018	89.0
284 970	Pull beam for pipe Ø 800 mm	0.80		20.0
284 940	Pull beam for pipe Ø 1,000 mm	1.00		32.0
284 950	Pull beam for pipe Ø 1,300 mm	1.30		40.0
284 960	Pull beam for pipe Ø 1,800 mm	1.80		42.0

l Length

d Diameter

G Weight

Pipe gripper RG 2500/RG 5000



Gripper heads

Art. no.	Short description	G [kg]	Load-bearing capacity [kg]
282 150	Gripper head for RK I / 2.5 t	106.0	2,500.0
282 160	Gripper head for RK II / 5.0 t	222.0	5,000.0

Gripper arms

Art. no.	Short description	Outside pipe diameter [mm]	G [kg]	Load-bearing capacity [kg]
282 120	Gripper arm type 50 (RK I/2.5 t)	275–640	30.0	2,500.0
282 130	Gripper arm type 80 (RK I/2.5 t)	590–960	34.0	2,500.0
282 140	Gripper arm type 90 (RK II/5.0 t)	700–1,090	42.0	5,000.0
282 100	Gripper arm type 125 (RK II/5.0 t)	1,090–1,390	72.0	5,000.0
282 110	Gripper arm type 150 (RK II/5.0 t)	1,300–1,740	80.0	5,000.0

Fall protection (rail guard)



Components

Art. no.	Short description	G [kg]	l [m]
880 800	Railing post, fall protection	4,6	1,00
880 900	Attachment for shoring, fall protection	7,0	
880 901	Attachment for sheet pile wall, fall protection	3,5	
880 801	Railing post extension	2,6	0,50

Trench struts

TITAN terra trench strut
acc. to DIN 4124



TITAN terra trench strut for wood shoring *

Ordering code	Adjustment range approx. [cm]	Admissible load [kN]	Weight approx. [kg]
terra spindle	30	–	2,1
terra Gr. 1	50–80	38–30	3,6
terra Gr. 1a	60–90	36–29	4,0
terra Gr. 2	80–110	34–29	4,6
terra Gr. 3	110–140	29–23	5,5
terra Gr. 4	140–170	26–22	6,5

TITAN 48 trench strut
acc. to DIN 4124



TITAN 48 trench strut for wood shoring *

Ordering code	Adjustment range approx. [cm]	Admissible load [kN]	Weight approx. [kg]
Ti 48/120	70–117	63–48	8,0
Ti 48/150	90–150	61–45	10,0
Ti 48/210	120–210	60–38	13,0

TITAN 60 trench strut
acc. to DIN 4124

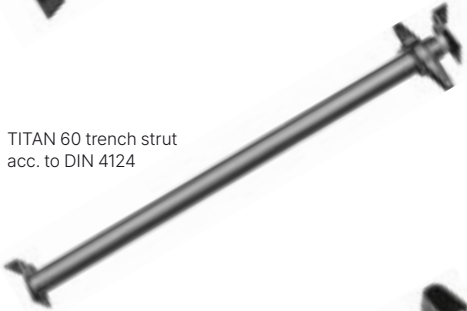

TITAN 60 trench strut for wood shoring *

Ordering code	Adjustment range approx. [cm]	Admissible load [kN]	Weight approx. [kg]
Ti 60 spindle	60	–	10,0
Ti 60/150	90–150	113–99	17,0
Ti 60/200	140–200	100–93	20,0
Ti 60/250	190–250	95–84	23,0
Ti 60/300	240–300	85–72	26,0

Gigant S with hook-type
angle for HEB 140–240



Gi-S trench strut for steel (HEB) waler

Type inspection number	Designation	Adjustment range approx. [cm]	Admissible load [kN]	Weight approx. [kg]
Gigant S TBG 3-Gi-S trench strut	Gi-S-120	70–120	210–177	26,0
	Gi-S-170	105–170	210–177	32,0
	Gi-S-210	140–210	184–156	36,0
	Gi-S-260	190–260	176–140	40,0
	Gi-S-310	240–310	157–138	45,0

Gi-SV trench strut with hook-type
angle for HEB 140–300



Gi-SV trench strut for steel (HEB) waler

Type inspection number	Designation	Adjustment range approx. [cm]	Admissible load [kN]	Weight approx. [kg]
Gigant SV TBG 3-Gi-SV trench strut	Gi-SV-210	140–210	548–290	69,0
	Gi-SV-260	190–260	471–260	81,0
	Gi-SV-310	240–310	424–260	92,0
	Gi-SV-380	310–380	310–380	107,0
	Gi-SV-450	380–450	380–450	122,0

Gi-SV-I spindle/non-adjustable
head with hook-type angle
for HEB up to 300

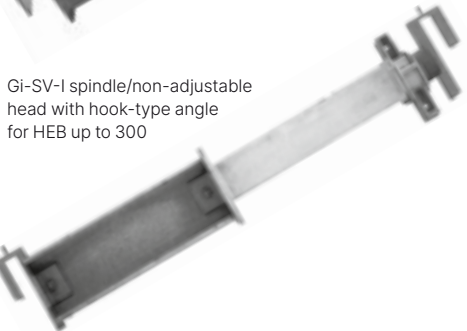

Gi-SV-I spindle/non-adjustable head for steel (HEB) waler

Type inspection number	Designation	Adjustment range approx. [cm]	Admissible load [kN]	Weight approx. [kg]
TBG 3-Gi-SV-I spindle/non-adjustable head	Gi-SV-I	72–97	448–393	50,0
	Gi-SV-I/F	–	448–393	5,0

* for sale only

terra infrastructure GmbH, Hollestr. 7a, 45127 Essen, Germany
P: +49 201 565 783 20
info@terra-infrastructure.com | www.terra-infrastructure.com

Australia

terra infrastructure Pty Ltd, 11 Woodford Pl, Thornton NSW 2322, Australia
P: +61 2 8448-3555
info.anz@terra-infrastructure.com
www.terra-infrastructure.com.au

New Zealand, Pacific Islands

terra infrastructure Pty Ltd, 180 Fred Taylor Drive, Whenuapai Auckland 0814, New Zealand
P: +64 9 416-8891
info.anz@terra-infrastructure.com
www.terra-infrastructure.co.nz

Baltic States

terra infrastructure UAB, Liepų str. 83, 93269 Klaipėda, Lithuania
P: +370 46 355-401
www.terra-infrastructure.com/lt

Russian Federation

OOO terra infrastructure, Bolshevikov Str. 54 B, Office 211, 193315 St. Petersburg, Russia
P: +7 812 337-6510
www.terra-infrastructure.com/ru

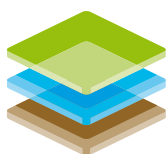

terra
infrastructure